

Heavy Duty Slurry Pumps

Sand, Sludge and Slurry



Precision Pumps supply high quality heavy-duty horizontal slurry pumps, vertical slurry pumps, replacement parts as well as pump services to a wide range of markets worldwide.

NR Series / Slurry Pumps



These pumps are designed for a wide range of erosive and/or corrosive applications. It is the world's standard for the most difficult mill duties by applying various kinds of metallic and elastomeric parts options and assortment of seals arrangements.

Elastomer Parts

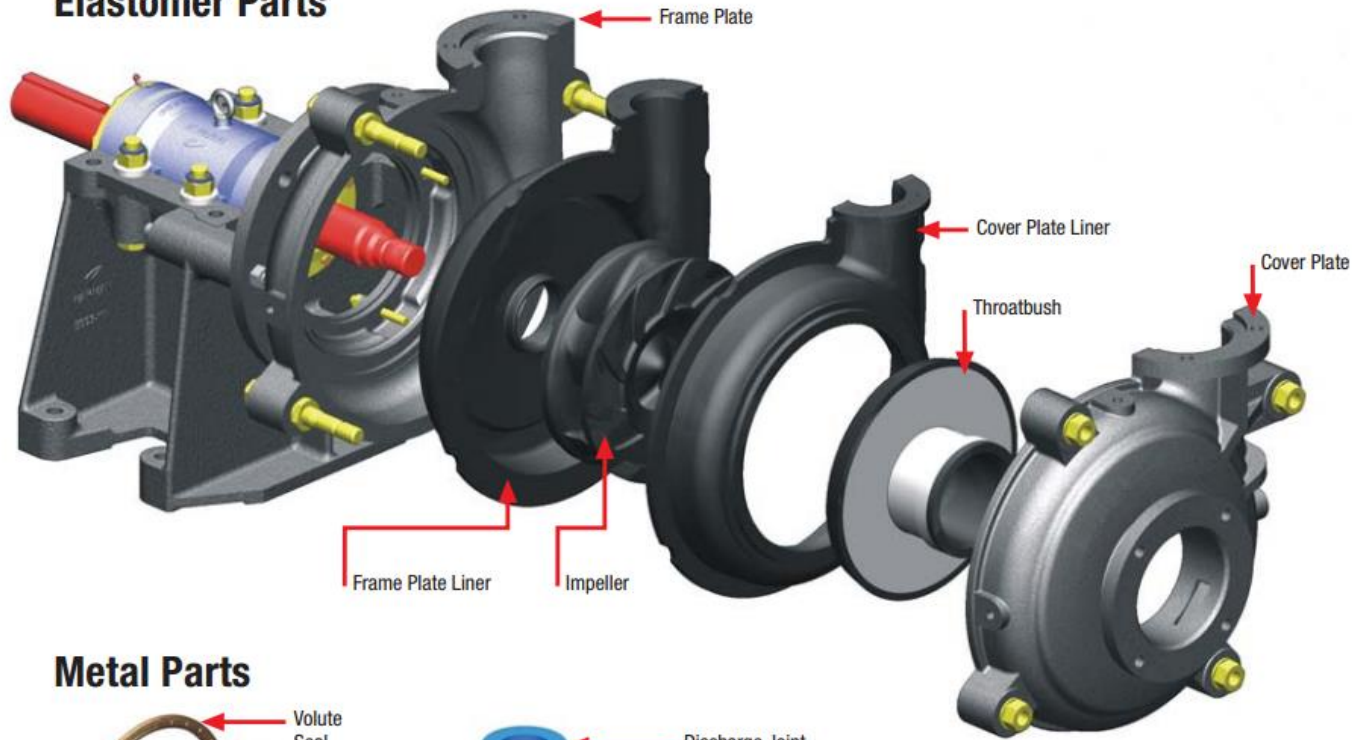

Metal Parts

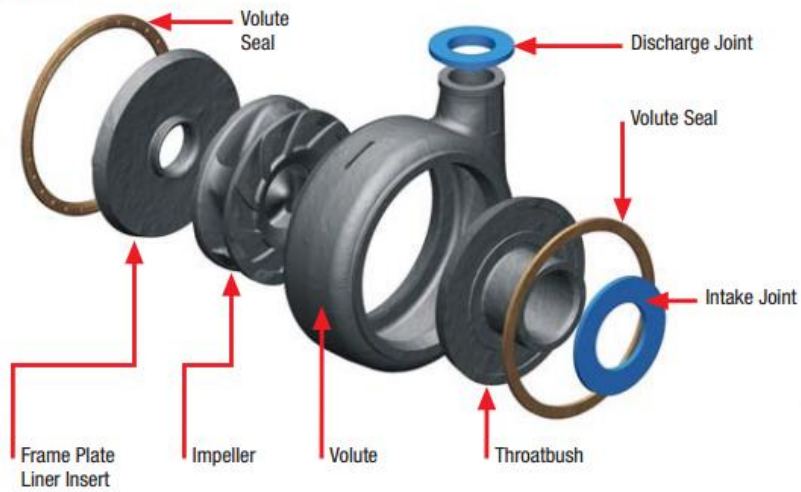

Applications

Wet crushers
Ball mill discharge
Coal
Coarse sand
Coarse tailings
Dredging
Fine tailings
Flotation
Heavy media
Mineral sands
Ni acid slurry
Oil sands
Phosphoric acid
Phosphate matrix
Process chemical
Pulp and paper
Rod mill discharge
SAG mill discharge

HH Series / Slurry Pumps



These pumps were designed specifically for continuous use in slurry applications where a high head per stage is required. Extensive exterior ribbing allows for higher heads to be reached with a single pump, and bulked up wet end parts handle the toughest applications in the field.

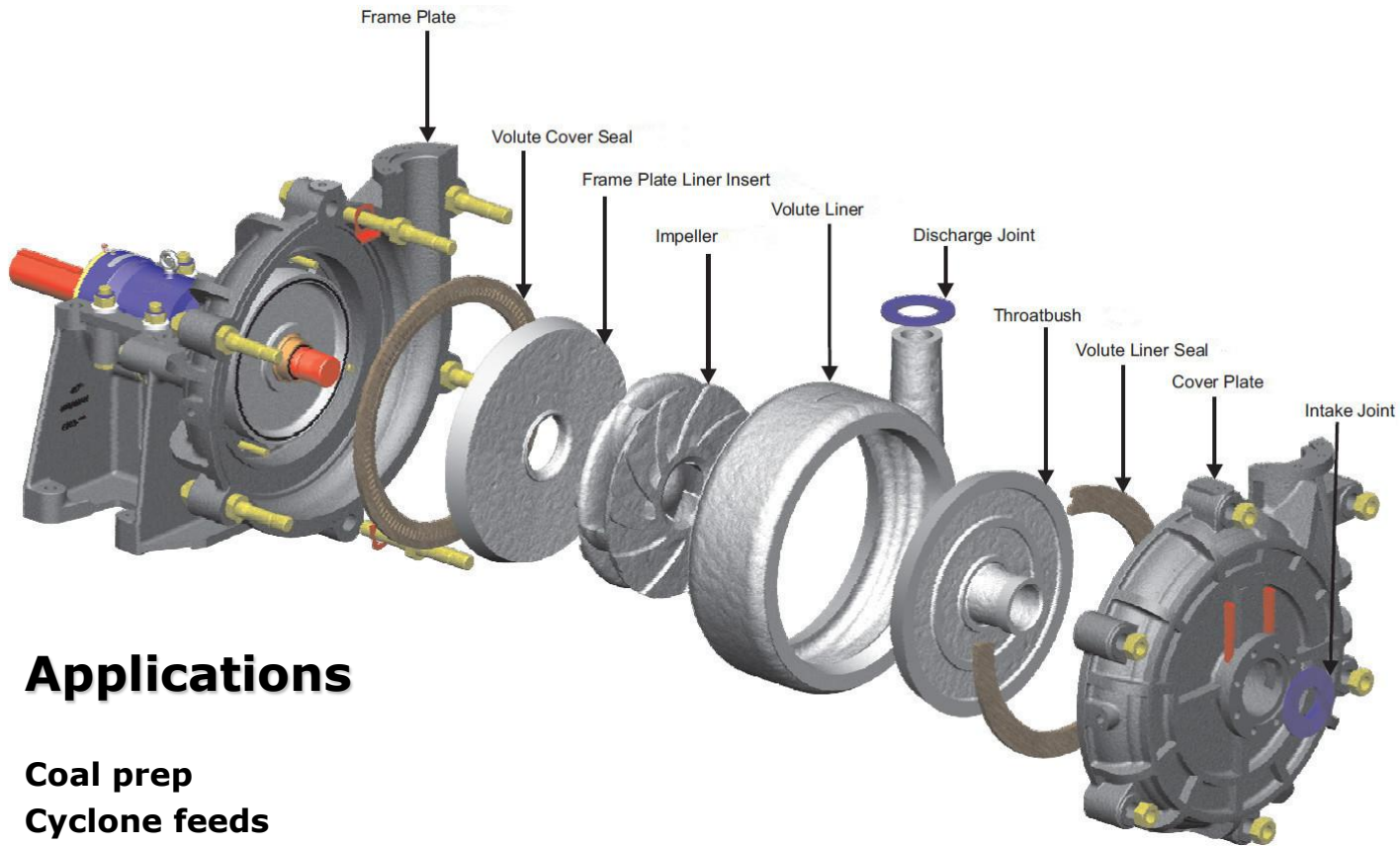

Applications

Coal prep

Cyclone feeds

Aggregate processing

Food processing

Cracking operations

Ash handling

Fine primary mill grinding

Chemical slurry service

Industrial processing

Pulp and paper

Pipeline transport

High velocity hydraulic transport

Mineral processing

L Series / Slurry Pumps



L series pump incorporates the same design points of the AH pump, but with a wider range of flow-rates and lower life-cycle costs. Higher efficiency impellers make the L Series a valuable feature in any plants.

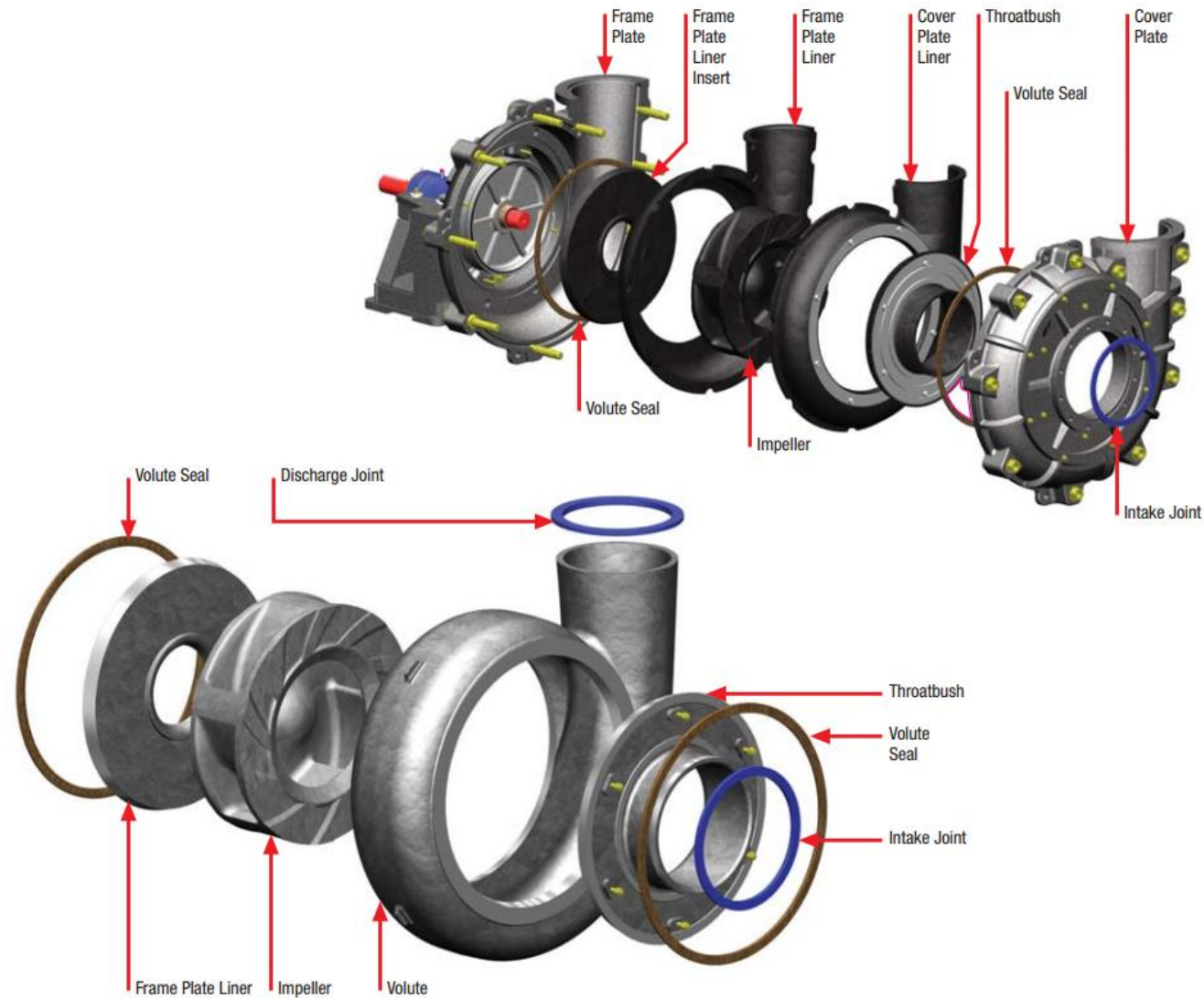

Applications

- FGD Application**
- Flash Cooler Circulation**
- Dilute Media**
- Slag Granulation**
- Mine Dewatering**
- Secondary Milling Circuits**
- Thickener Over and Underflow**
- Ball mill discharge**
- Rod mill discharge**

SP Series / Slurry Pumps



These sump pumps are an ultra heavy duty design for continuous operation in a variety of sump conditions. Handling abrasive slurries and corrosive fluids by using fully elastomer lined or hard metal wet end components.

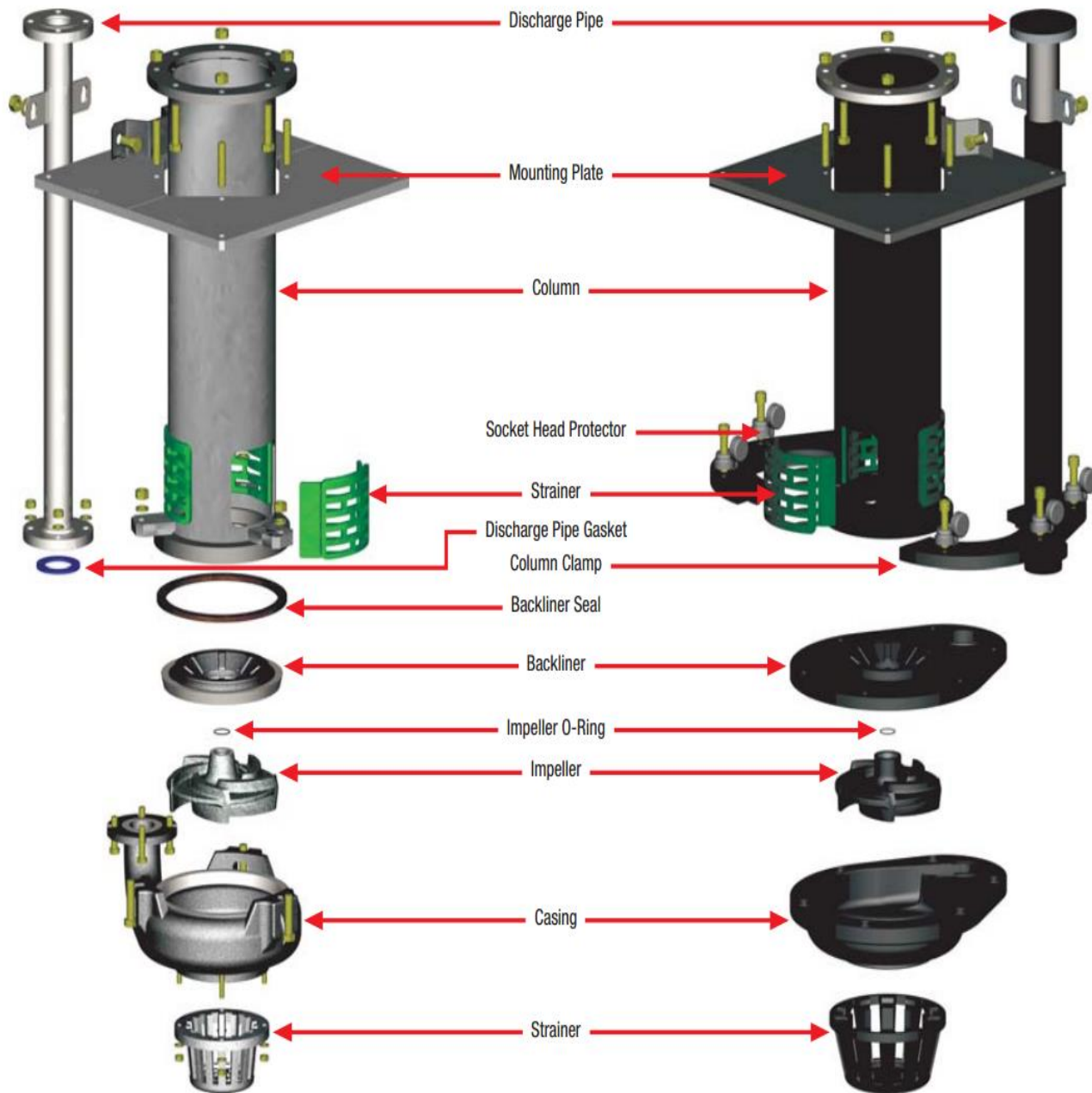

Applications

Gravel and sand
Mineral processing
Chemical processing
Coal preparation
Effluent handling
Floor sump pumping
Mill scale pumping
Wood chip pumping
Air entrained slurries
Sand Slurry
Process Sumps
Mill Sumps

Mission Sand/Mud Pumps

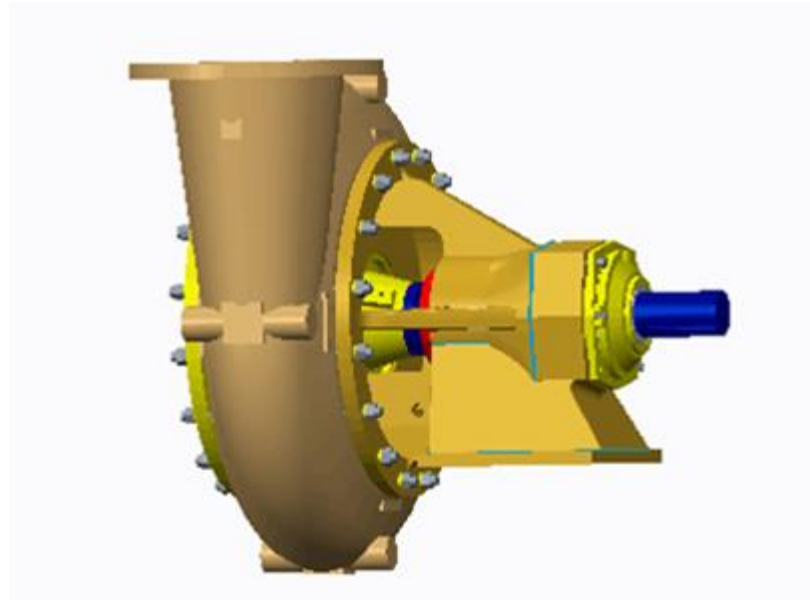
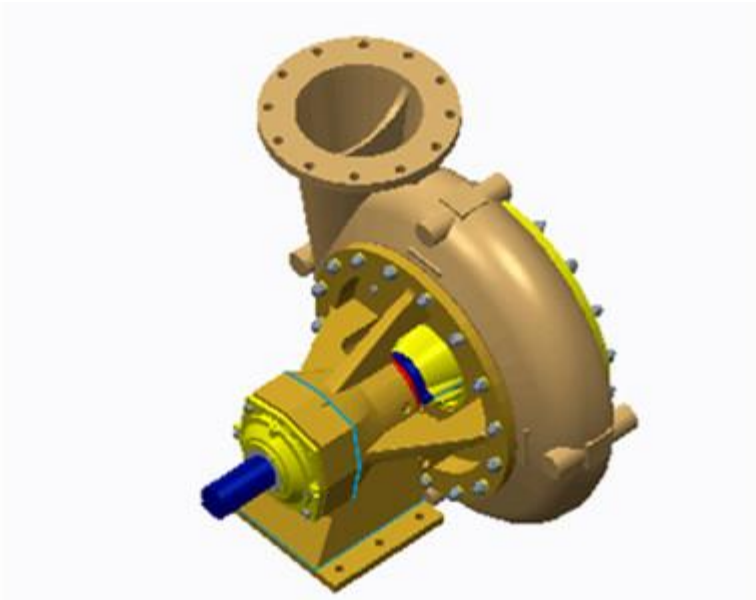

Our High Chrome 14X12X22 Pump is ideally suited for pumping high volumes of heavy slurries that are abrasive, corrosive. Other size refer to the following pages.
Flows to 1705 m³/h (7500 gpm)
Heads to 125 m (410 ft)

3X2-13

PRNM 3x2-13

speed: 1150RPM

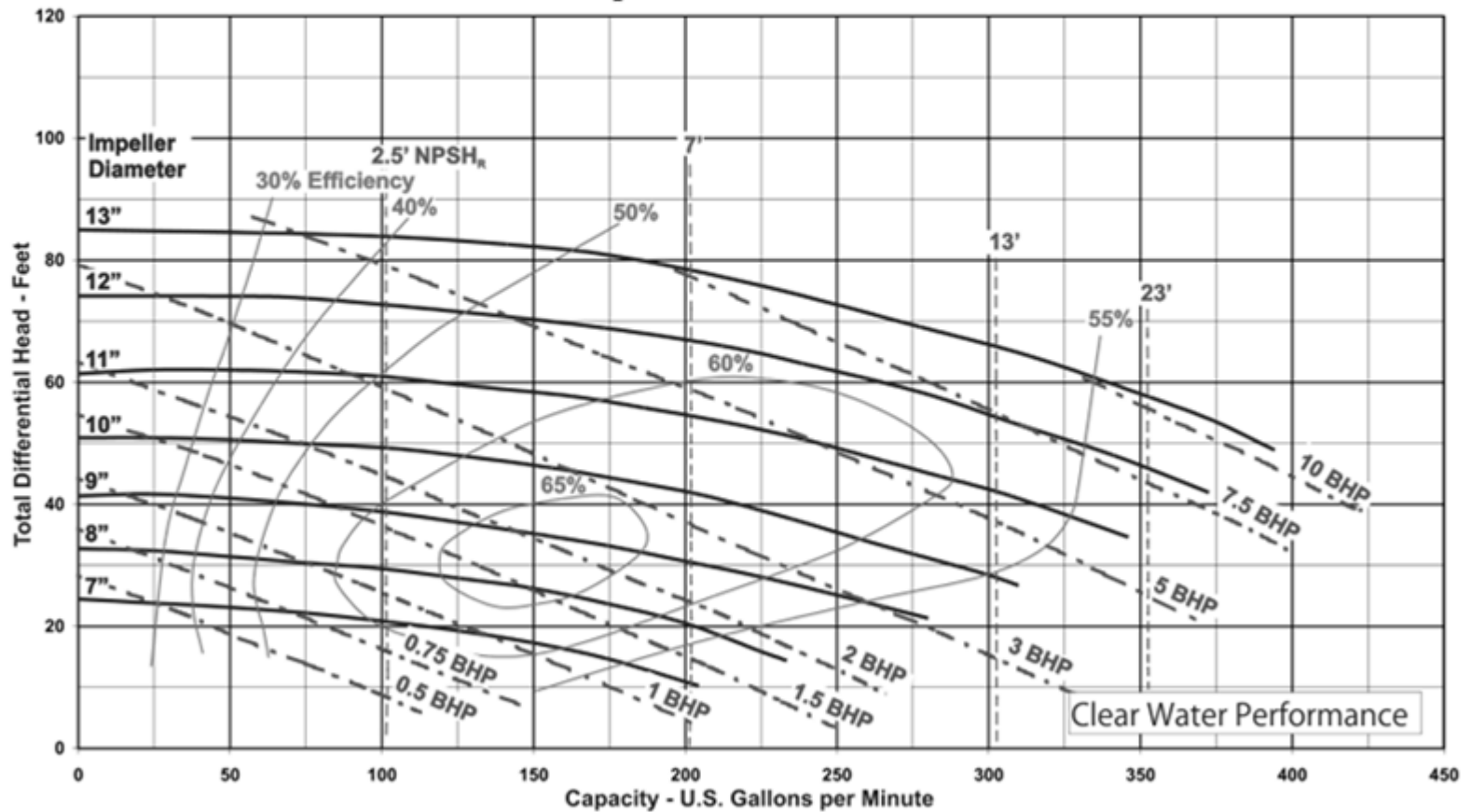

3X2-13

PRNM 3x2-13

speed: 1750RPM

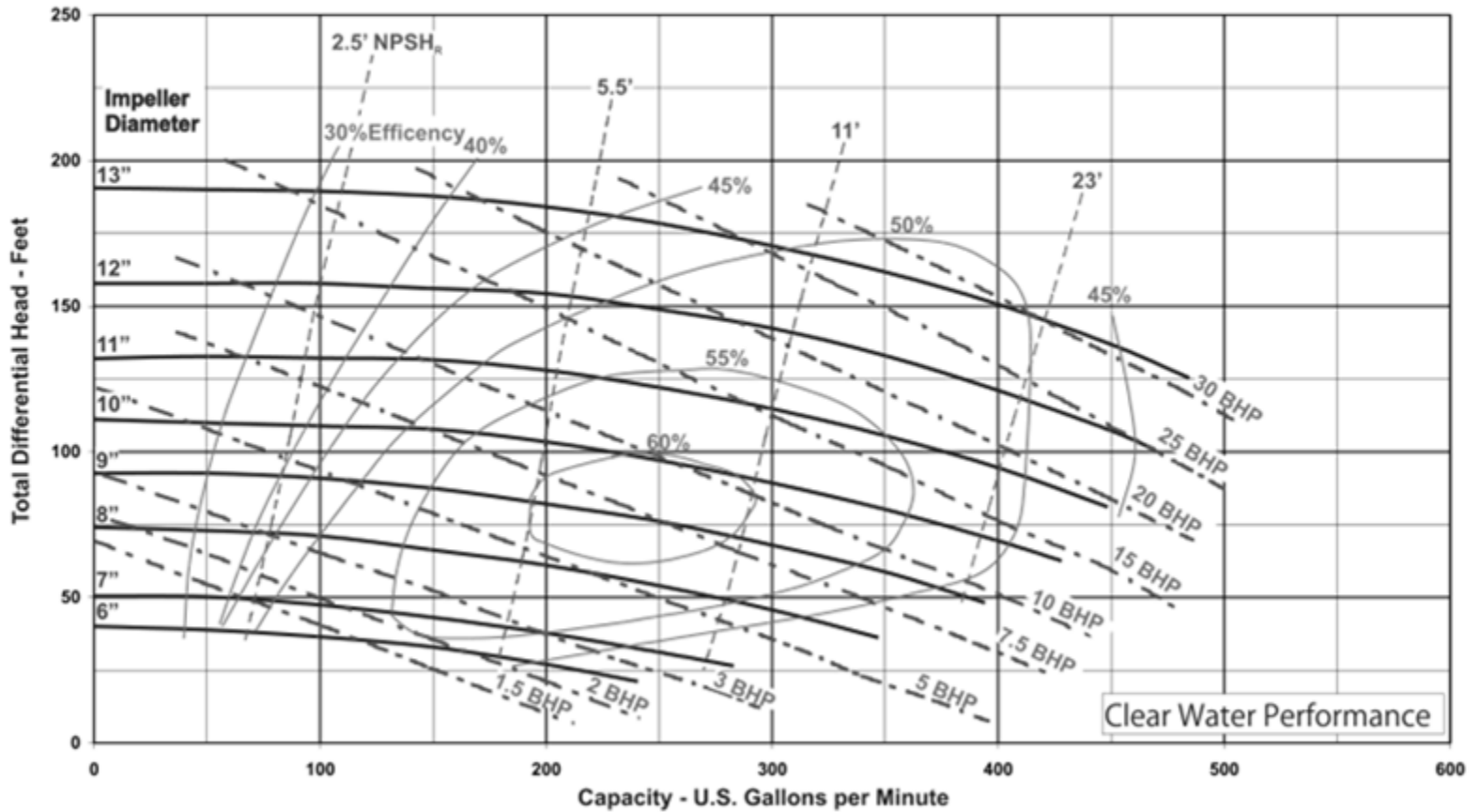

3X2-13

PRNM 3x2-13

Speed: 3500RPM

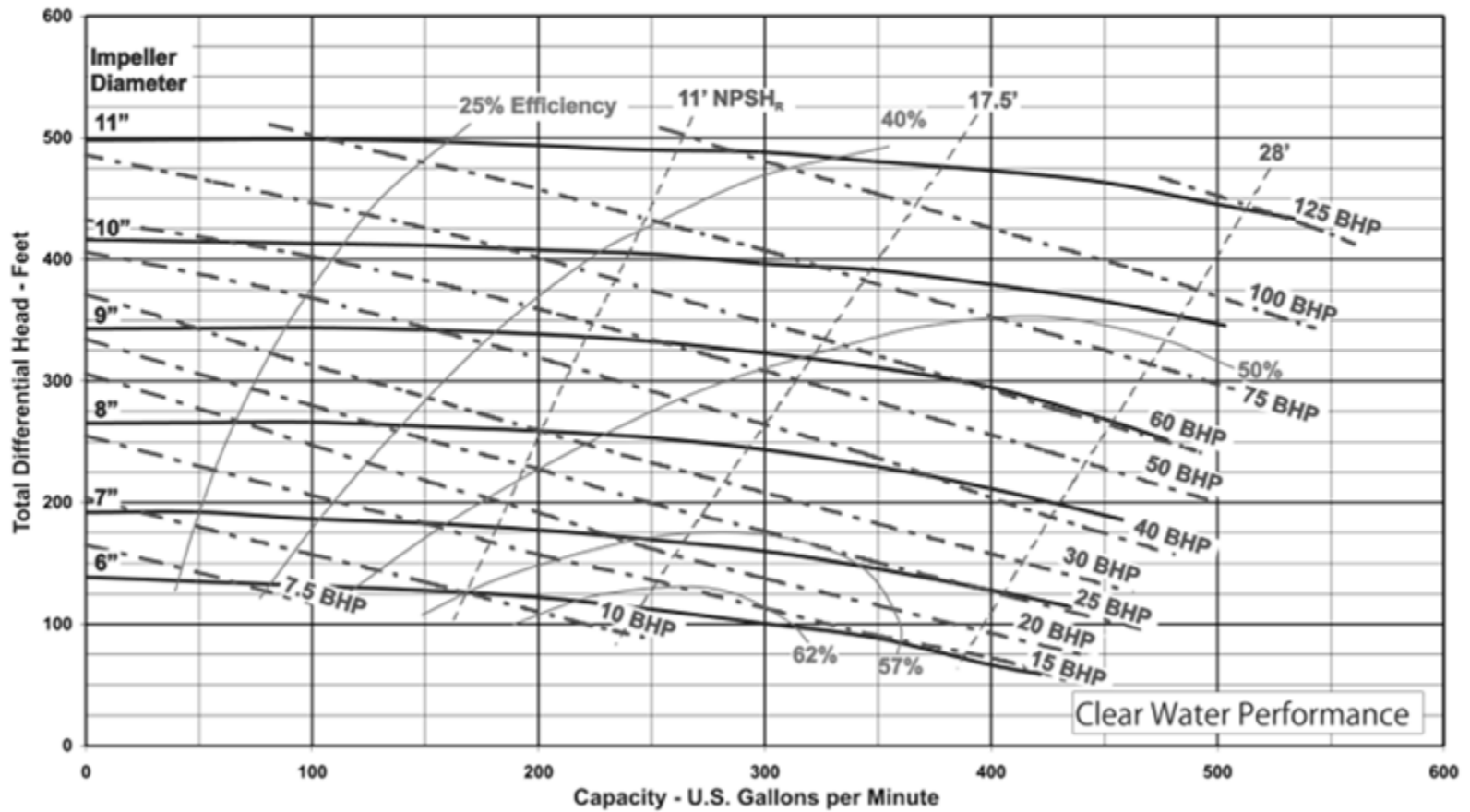

4X3-13

PRNM 4x3-13

Speed: 1150RPM

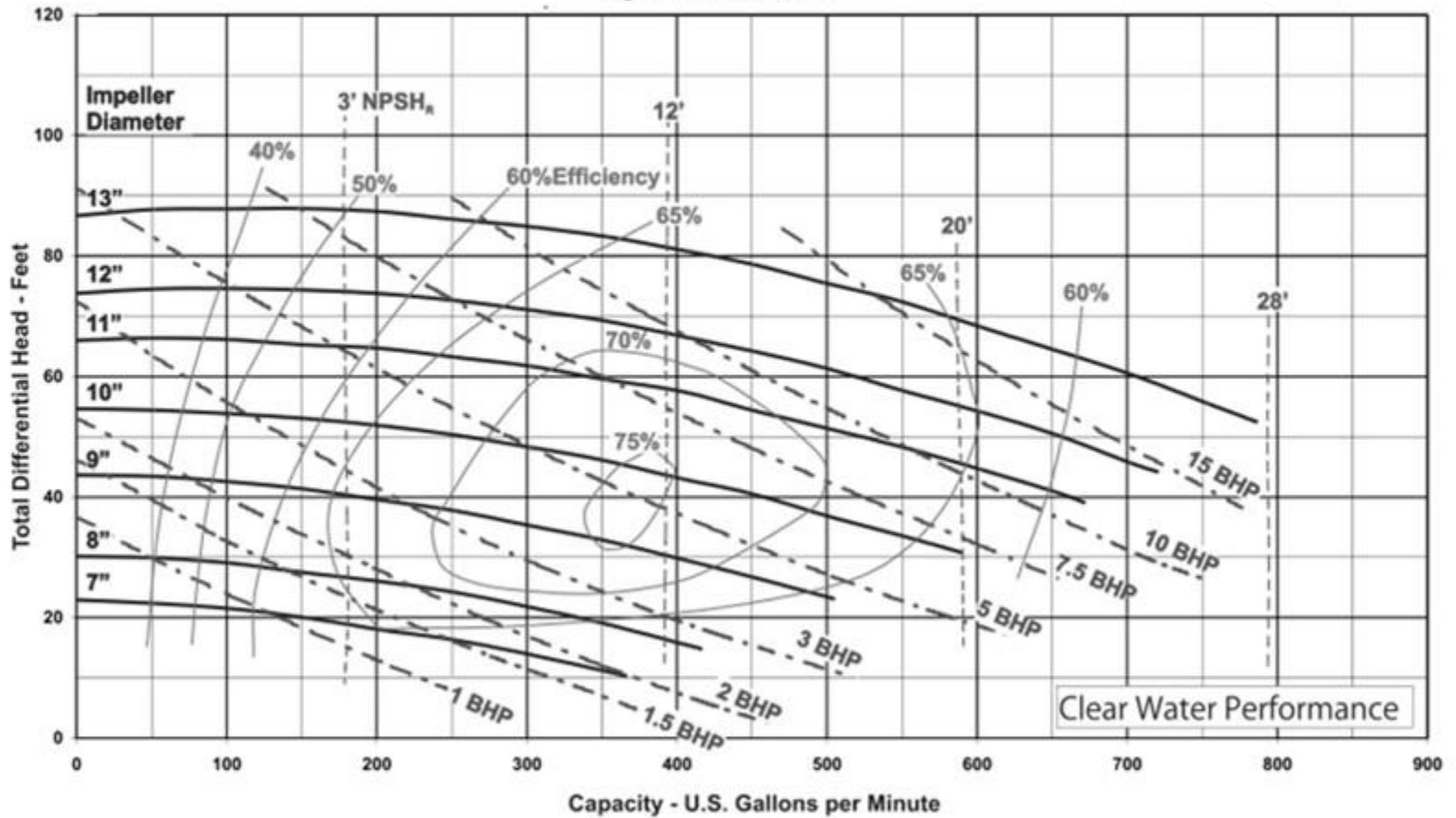

4X3-13

PRNM 4x3-13

Speed: 1750RPM

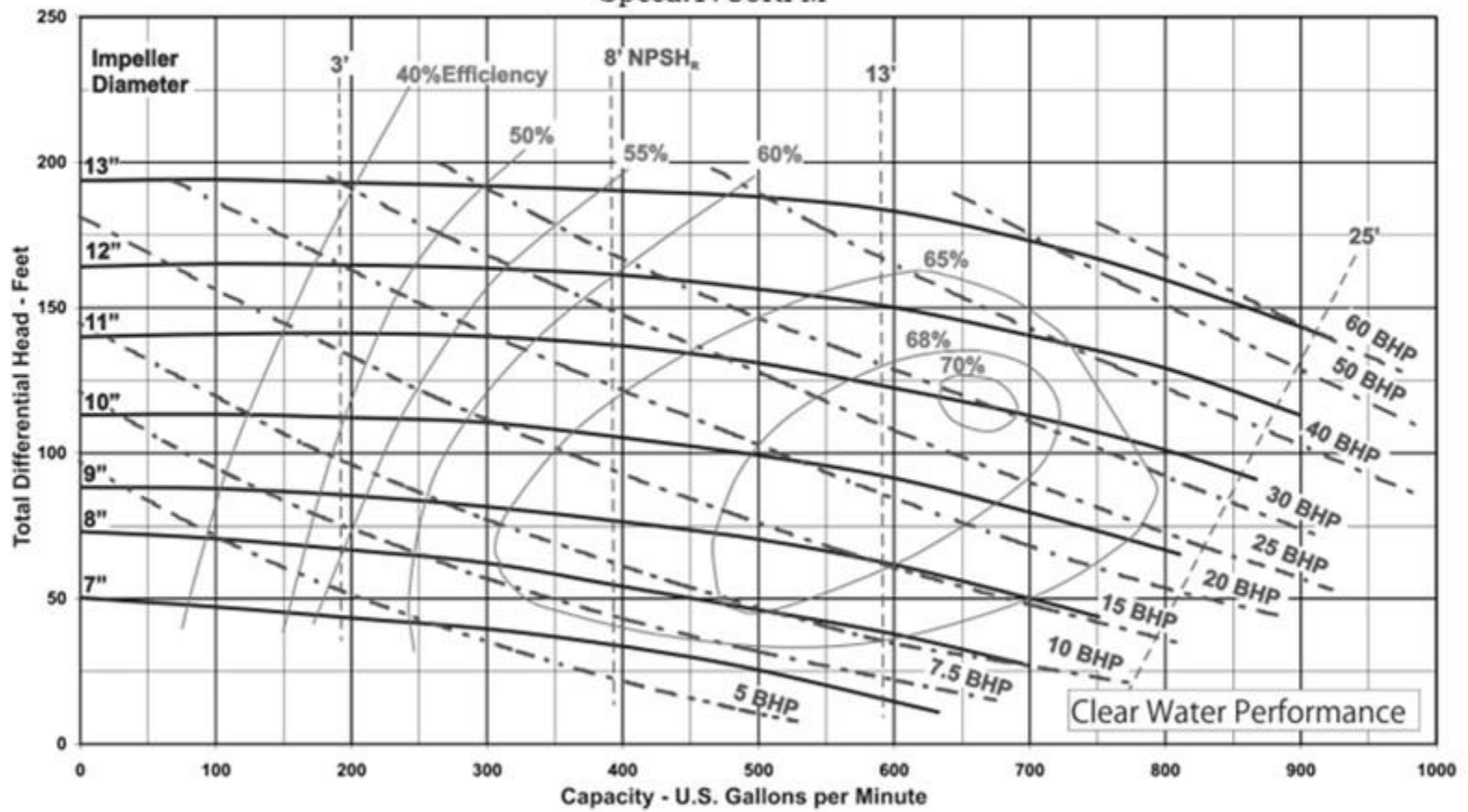

4X3-13

PRNM: 4x3-13

Speed: 3500 RPM

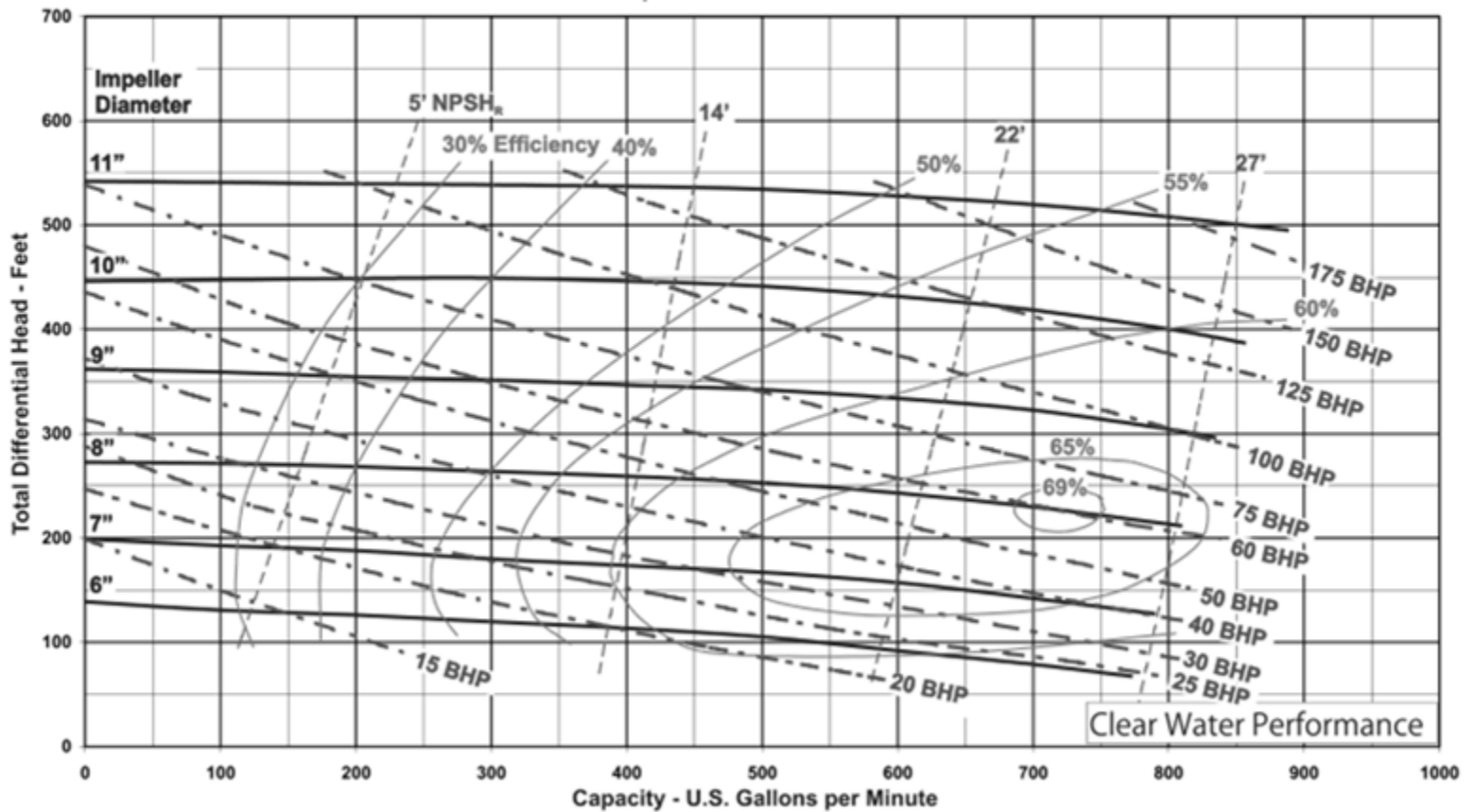

5X4-14

PRNM 5x4-14

Speed: 1150 RPM

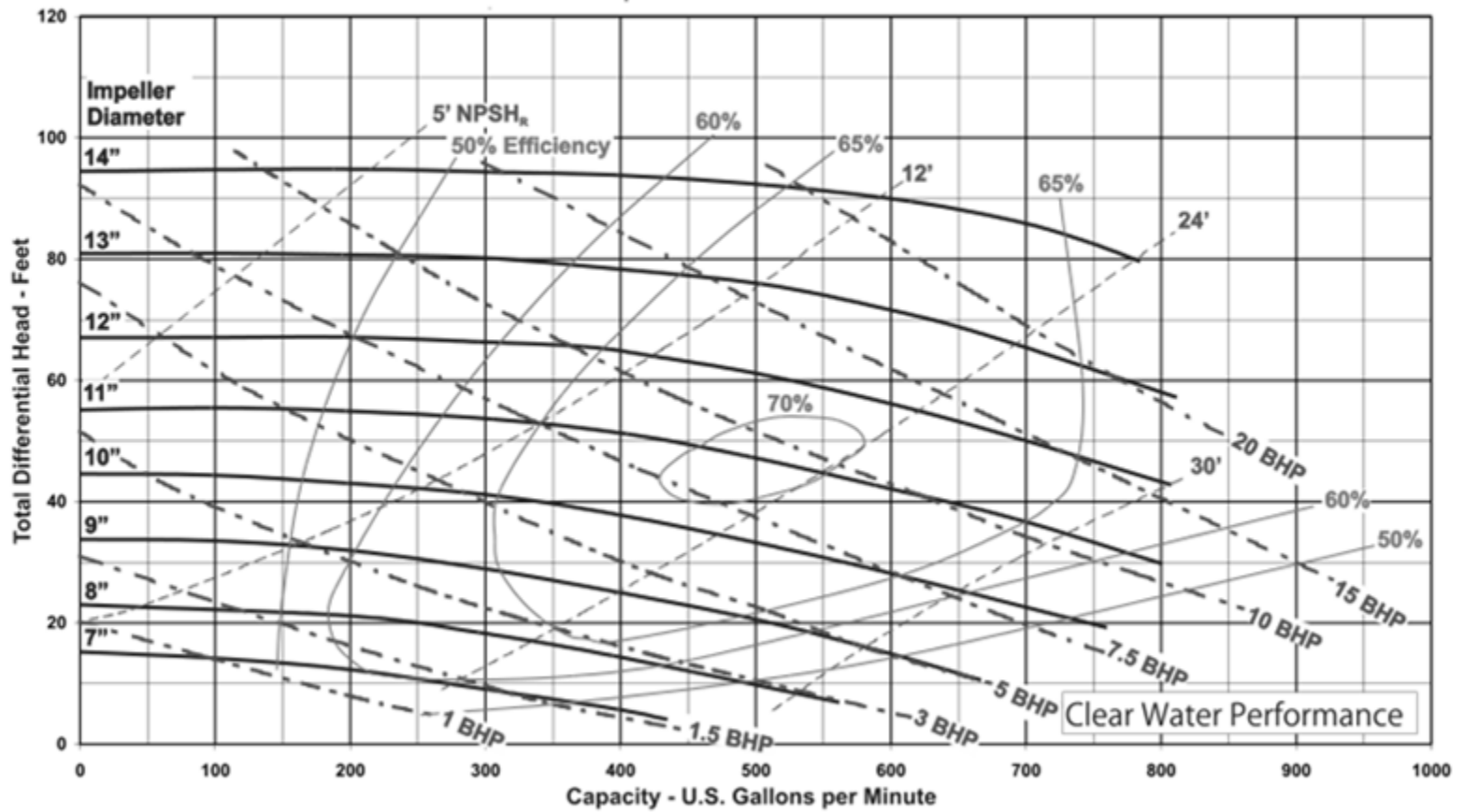

5X4-14

PRNM 5x4-14

Speed: 1750 RPM

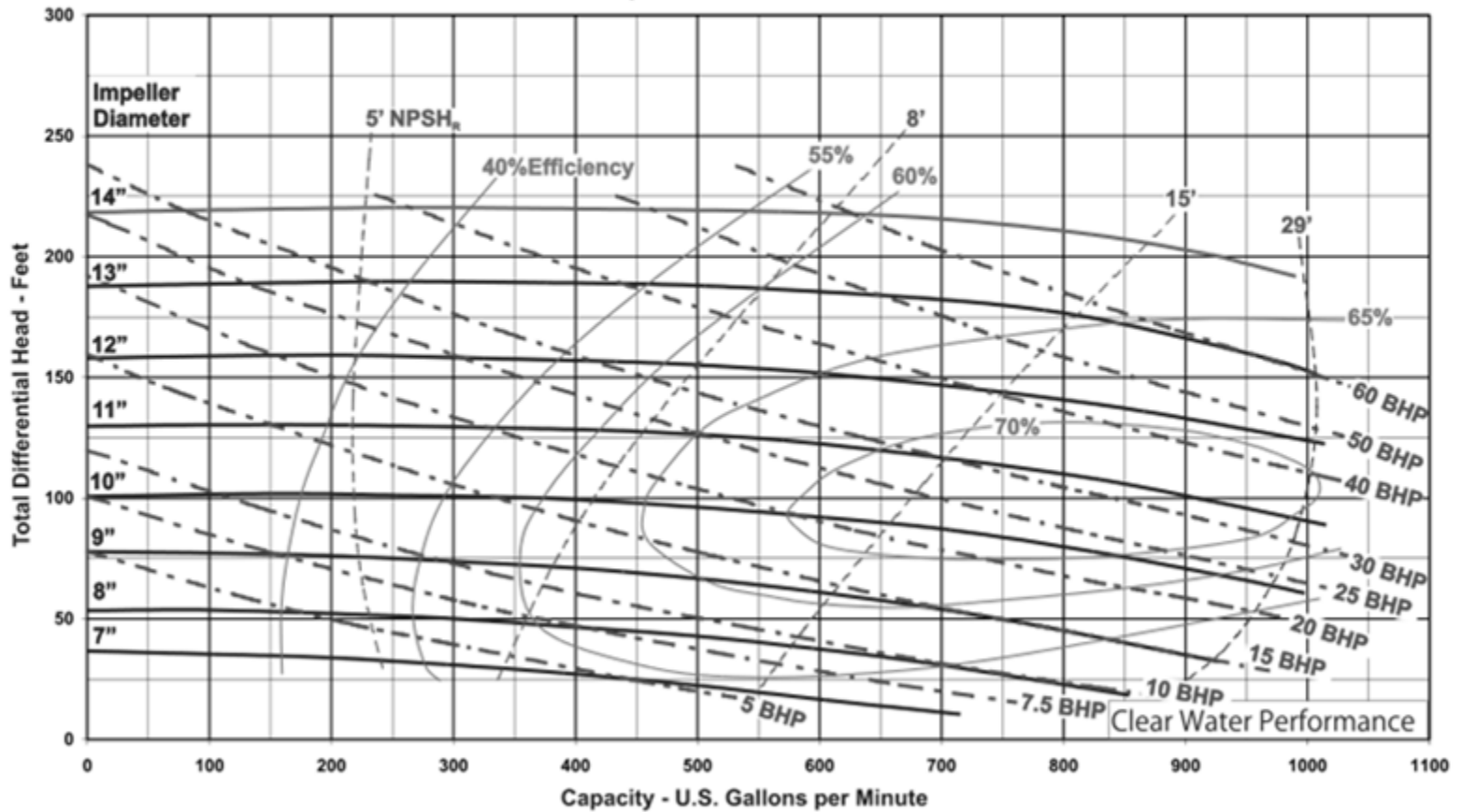

6X5-11

PRNM 6x5-11

Speed: 1150 RPM

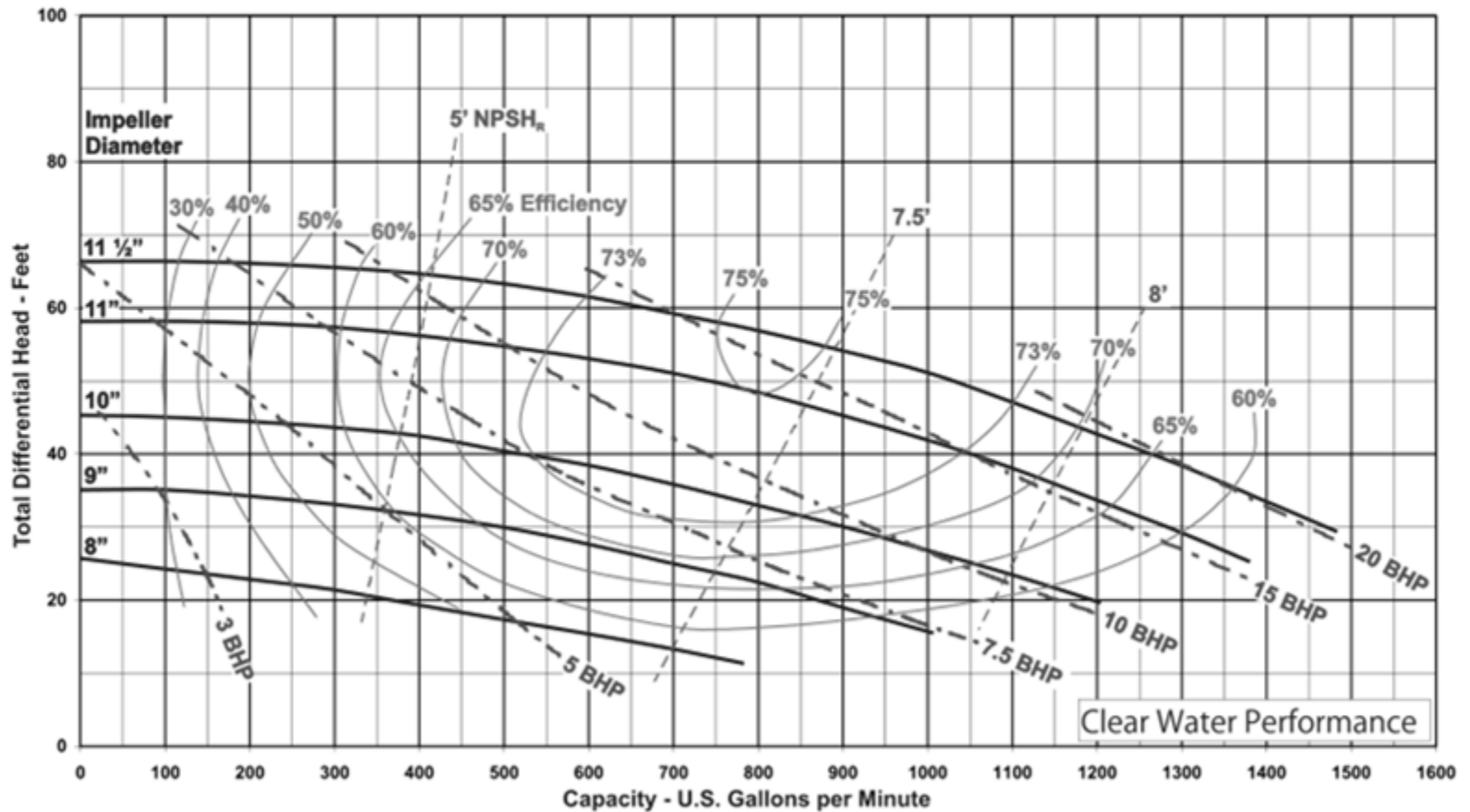

6X5-11

PRNM 6x5-11

Speed: 1750 RPM

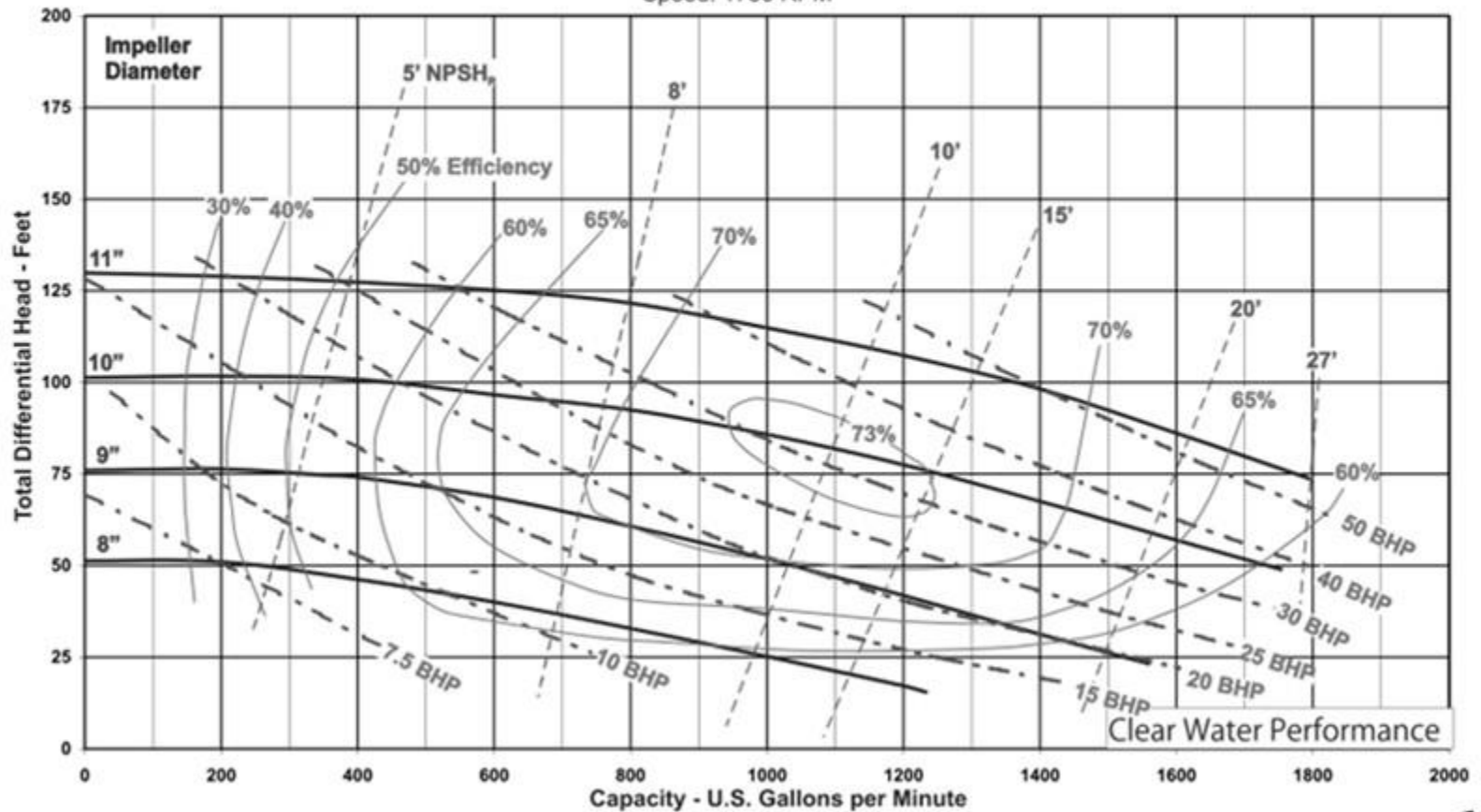

6X5-14

PRNM 6x5-14

Speed: 1150 RPM

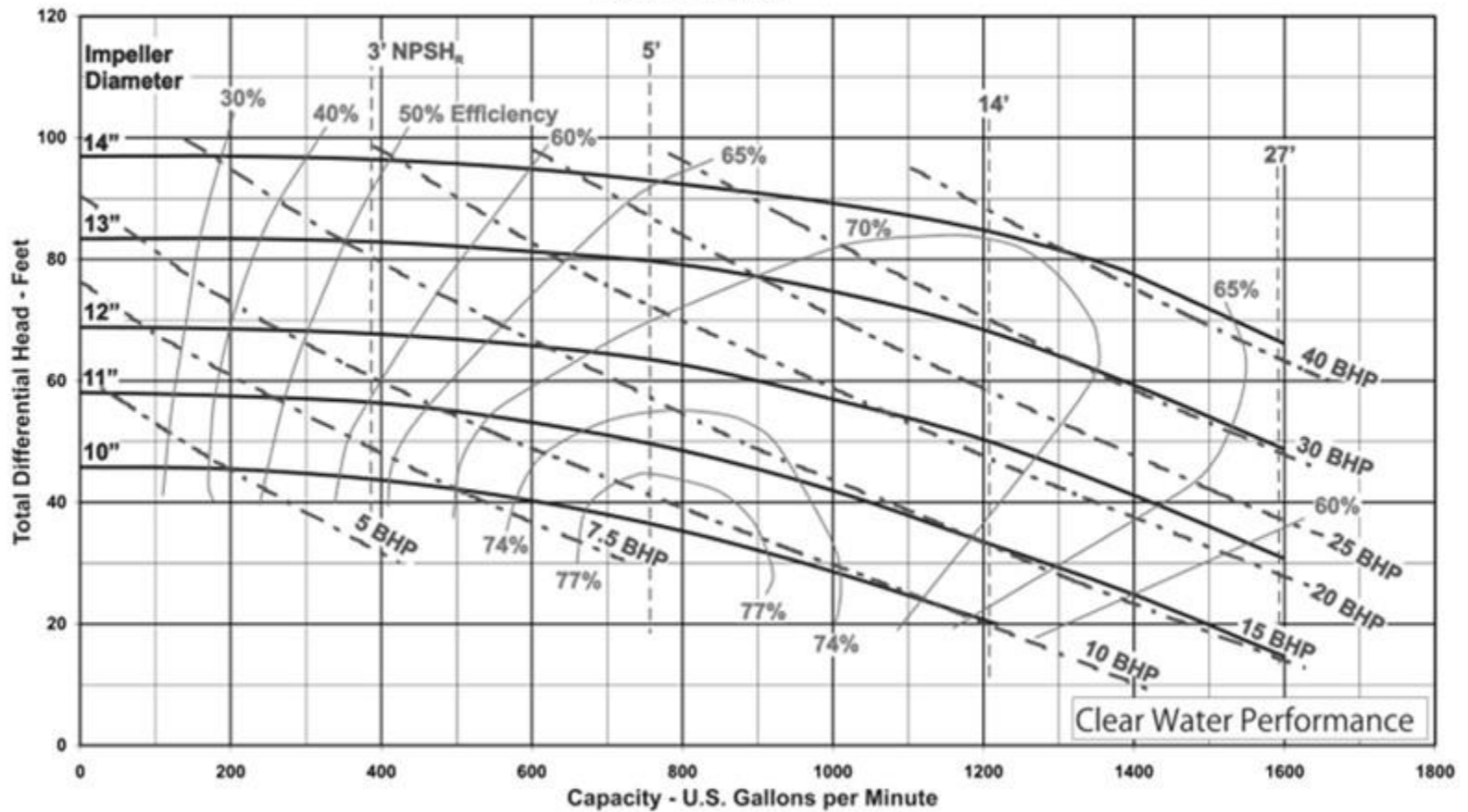

6X5-14

PRNM 6x5-14

Speed: 1750 RPM

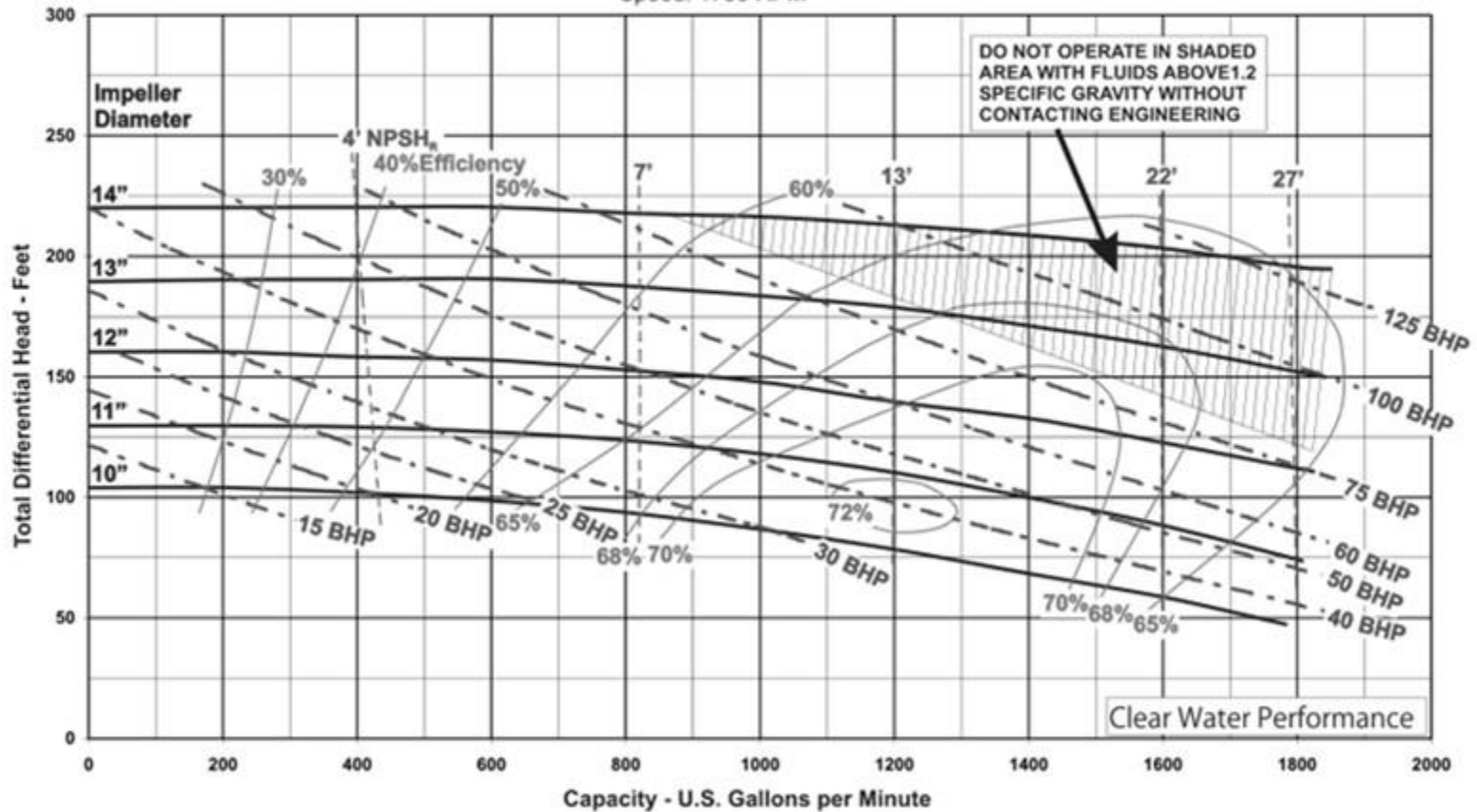

8X6-11

PRNM 8x6-11

Speed: 1150 RPM

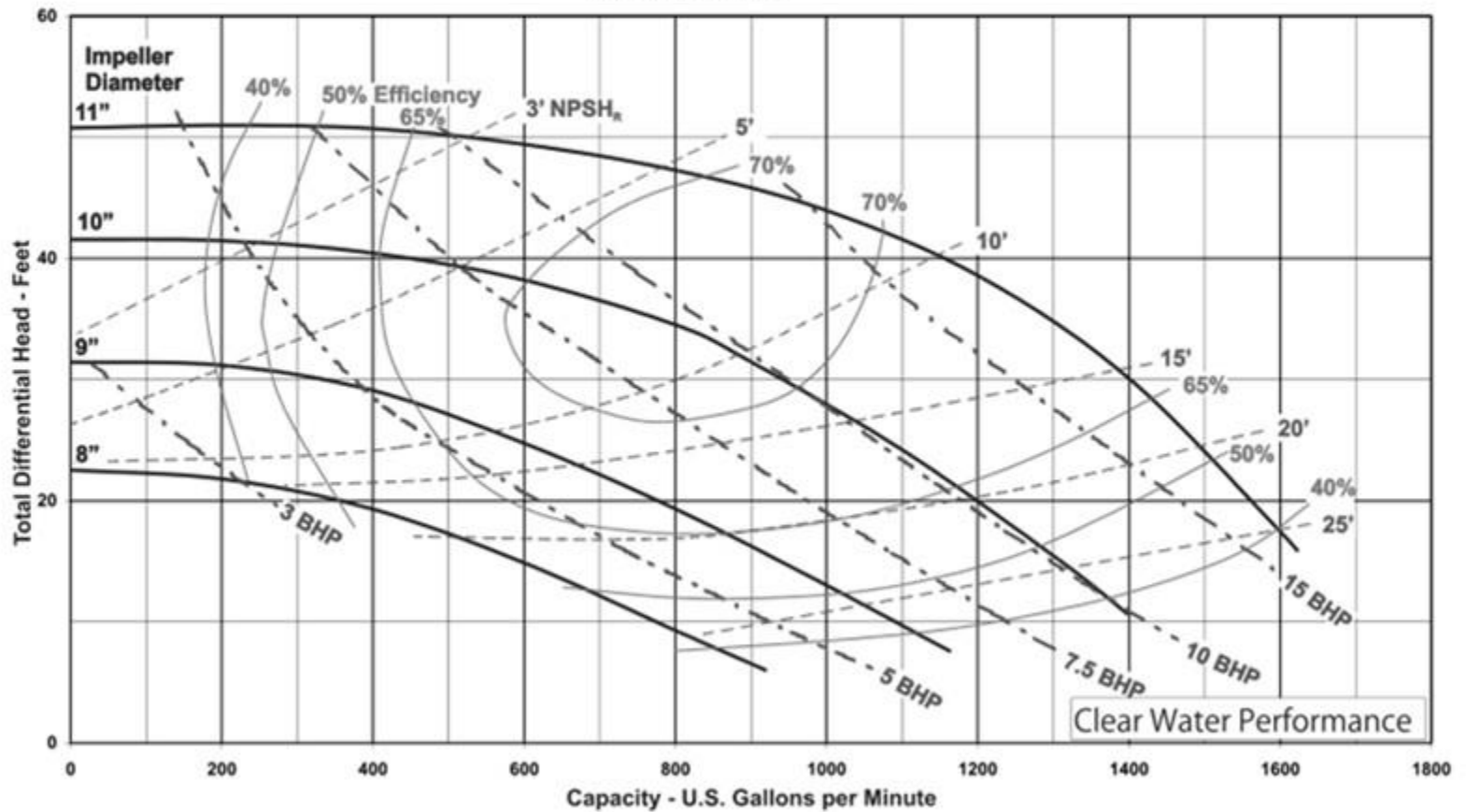

8X6-11

PRNM 8x6-11

Speed: 1750 RPM

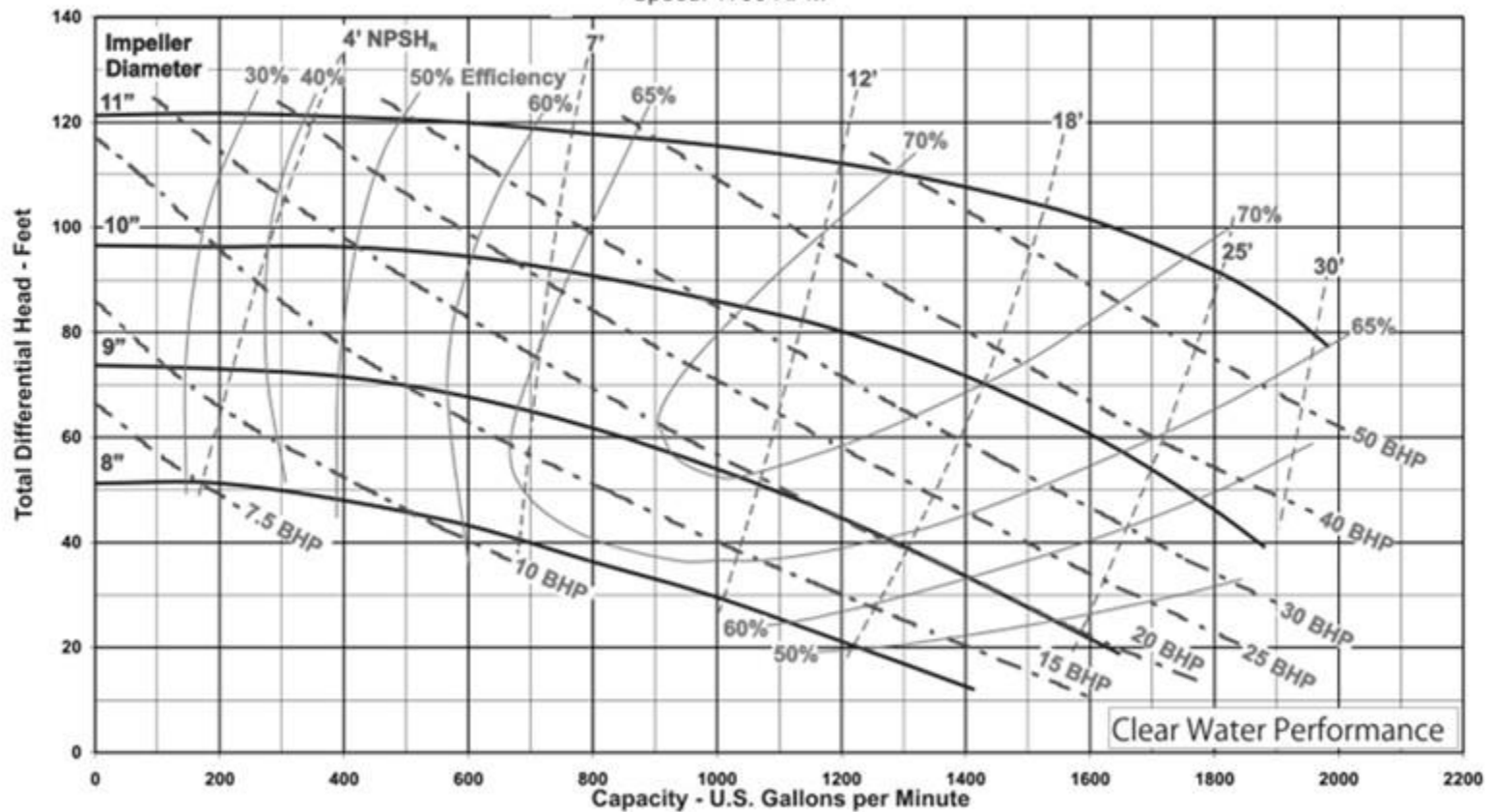

8X6-14

PRNM 8x6-14

Speed: 1150 RPM

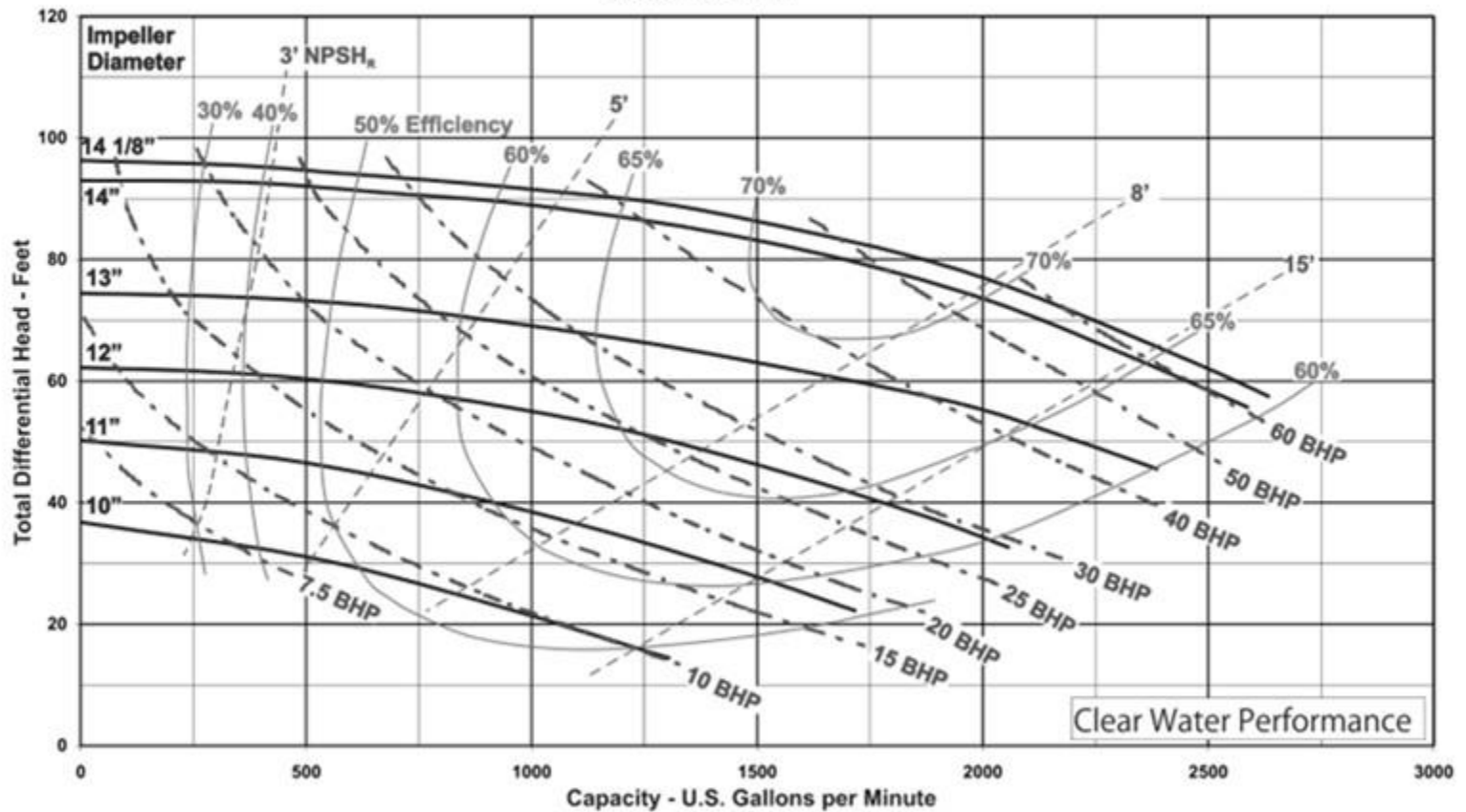

8X6-14

PRNM 8x6-14

Speed: 1750 RPM

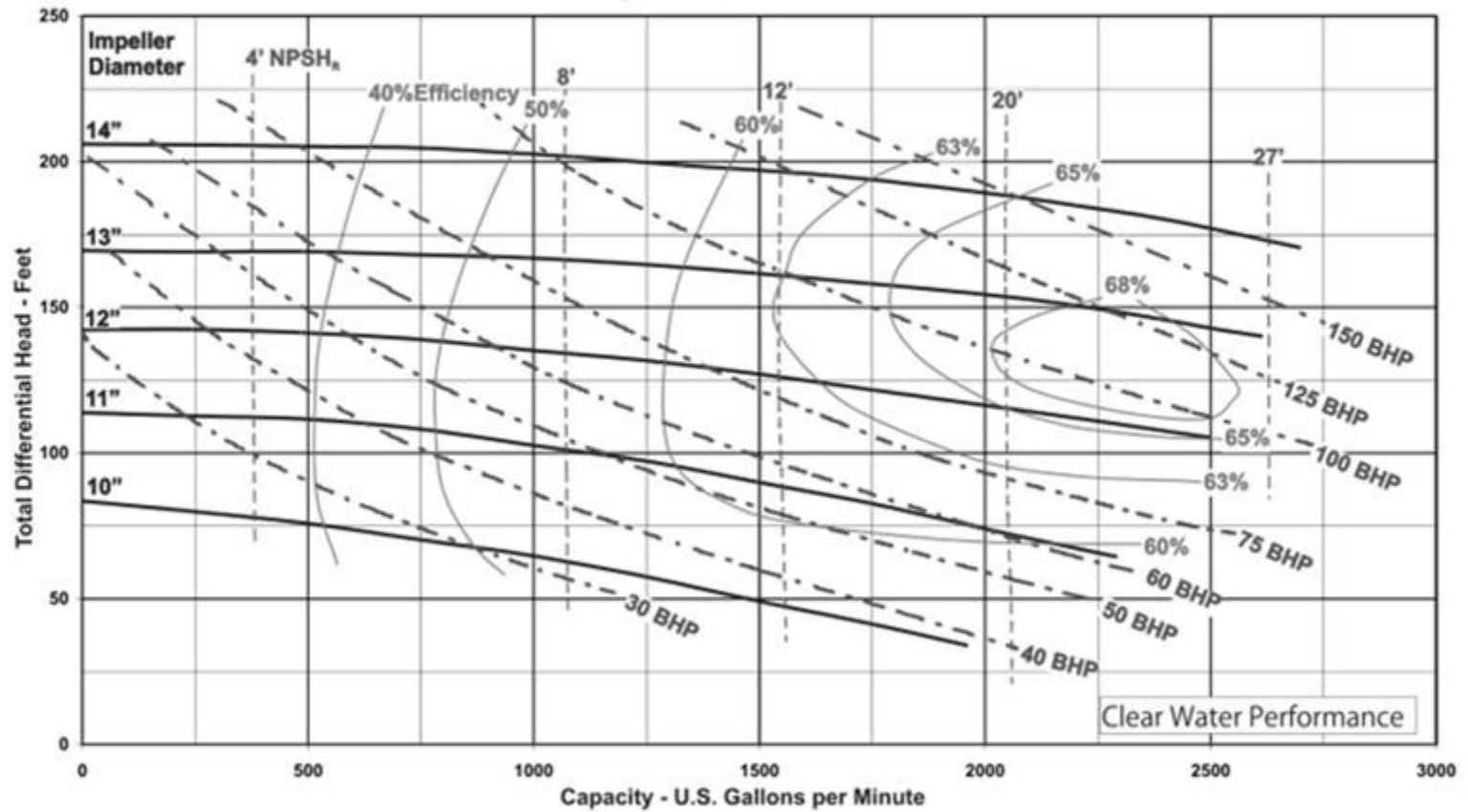

8X6-18

PRNM 8x6-18

Speed: 1750 RPM

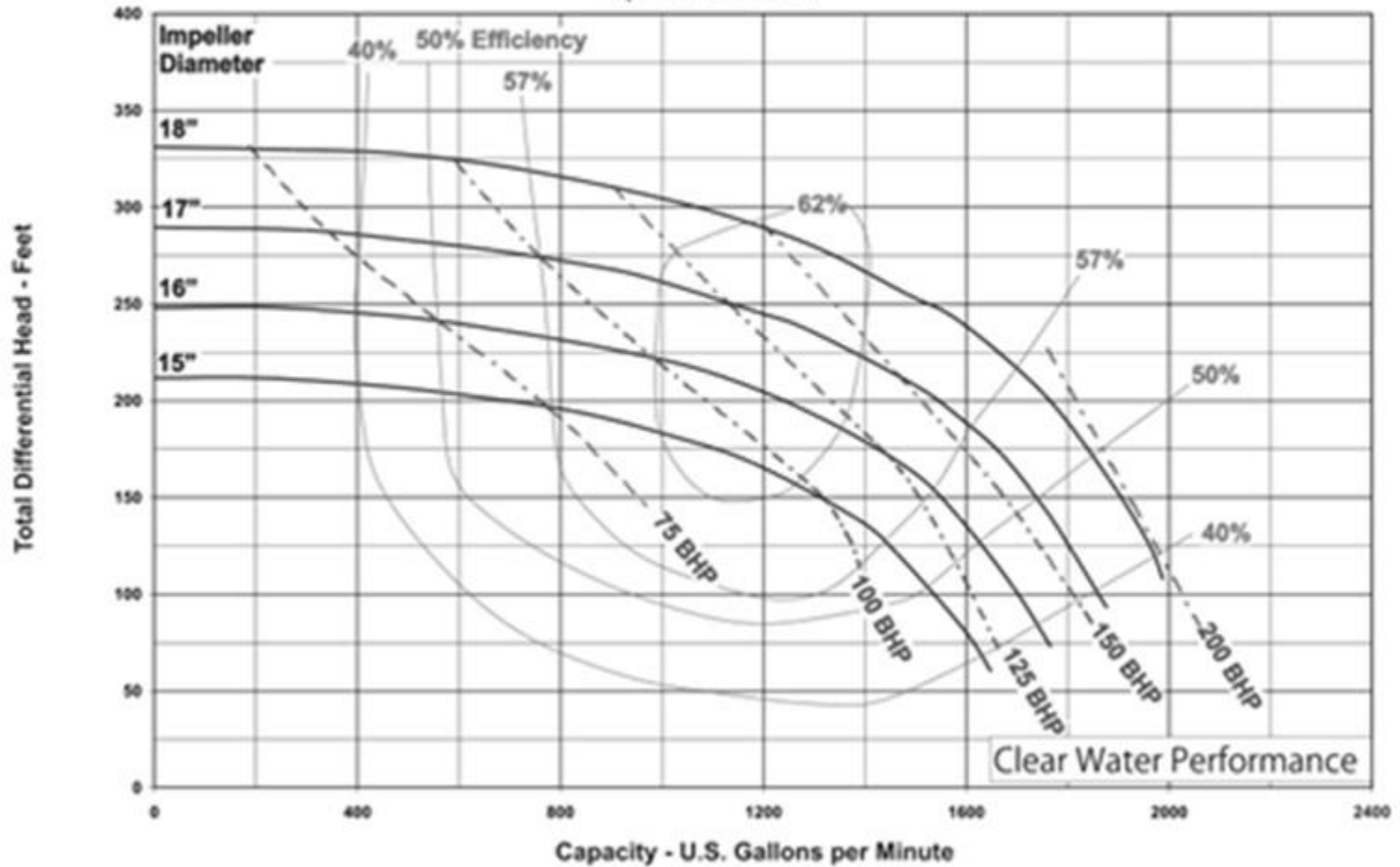

10X8-14

PRNM 10x8-14

Speed: 1150 RPM

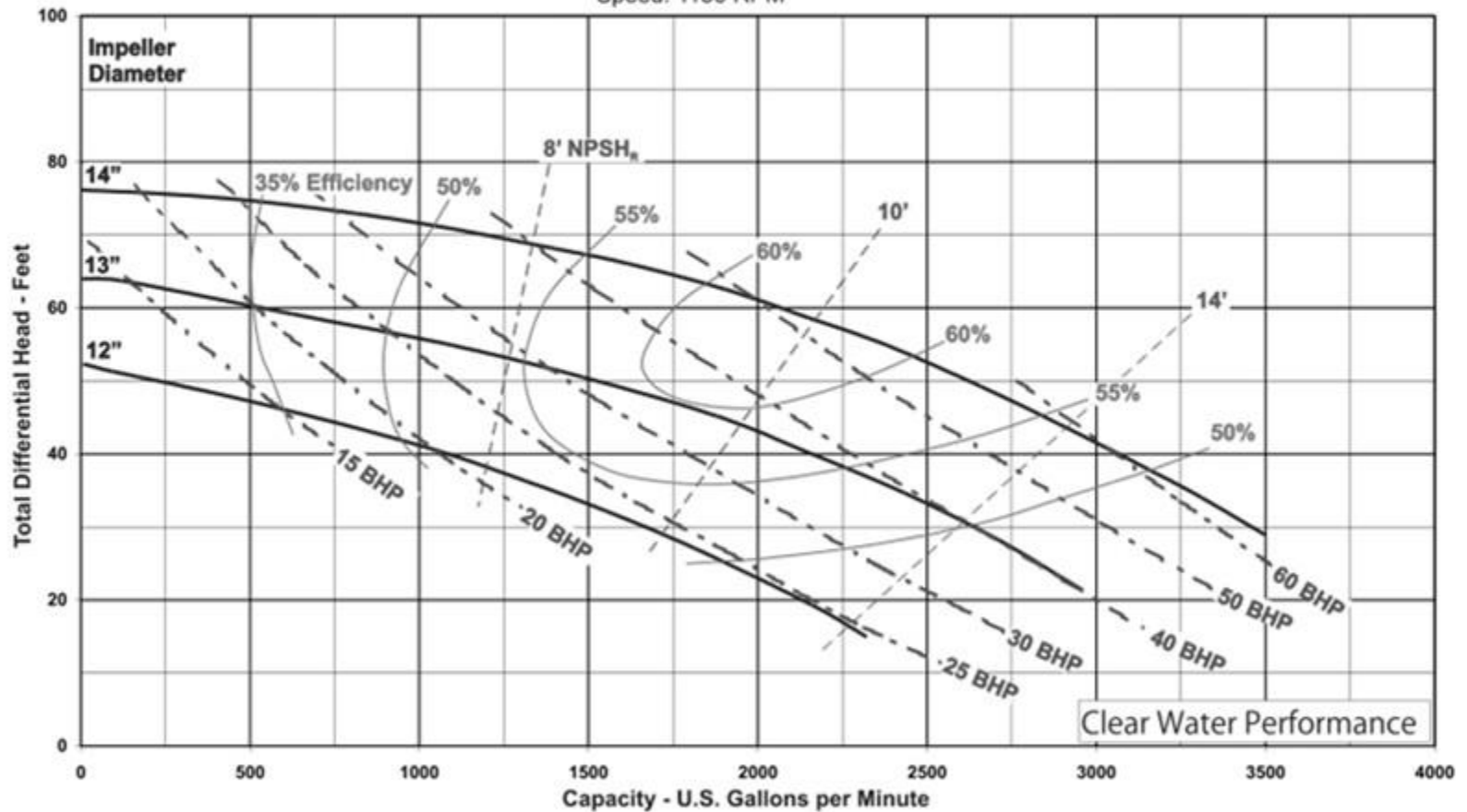

10X8-14

PRNM 10x8-14

Speed: 1750 RPM

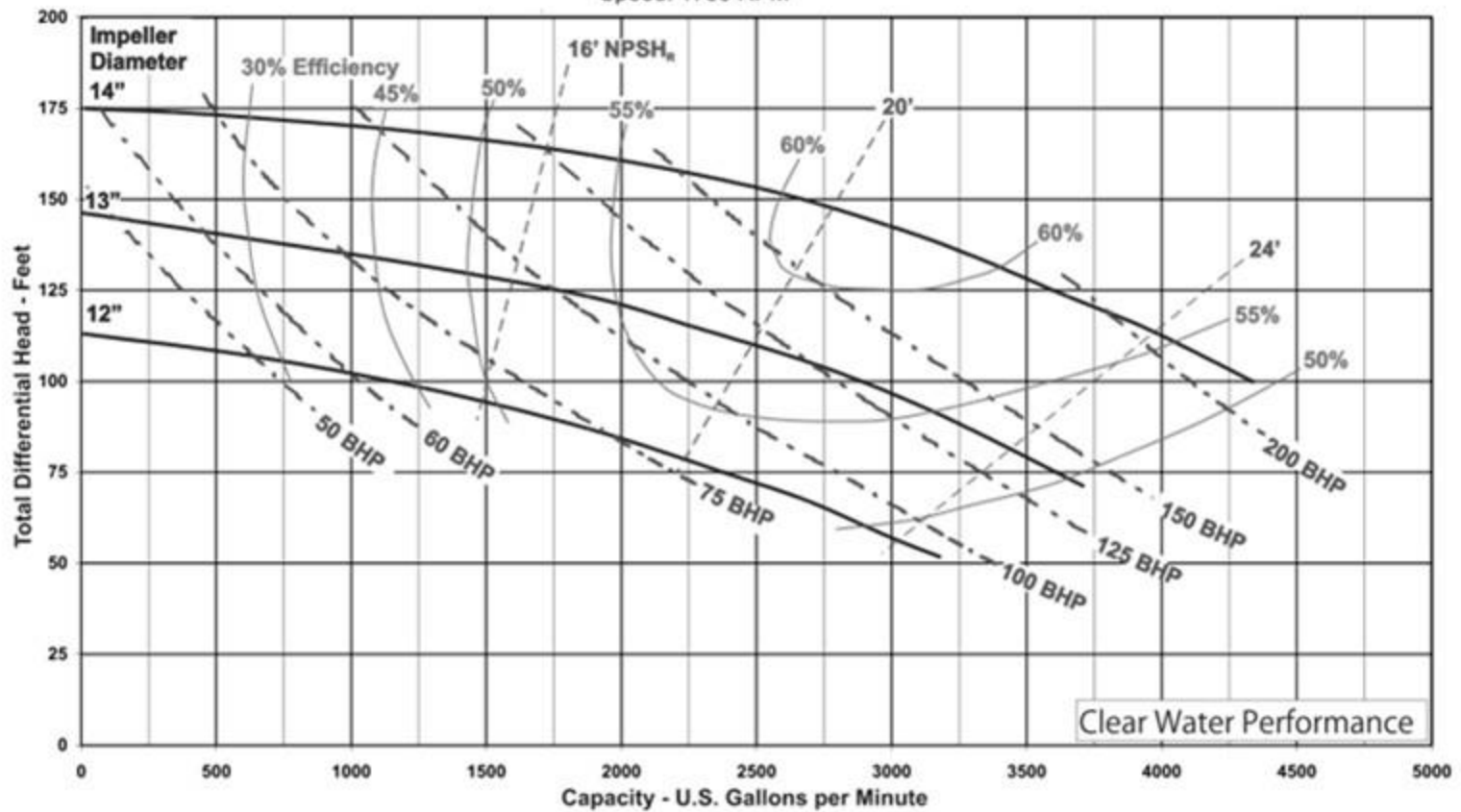

12X10-23

PRNM 12x10-23

Speed: 1200 RPM

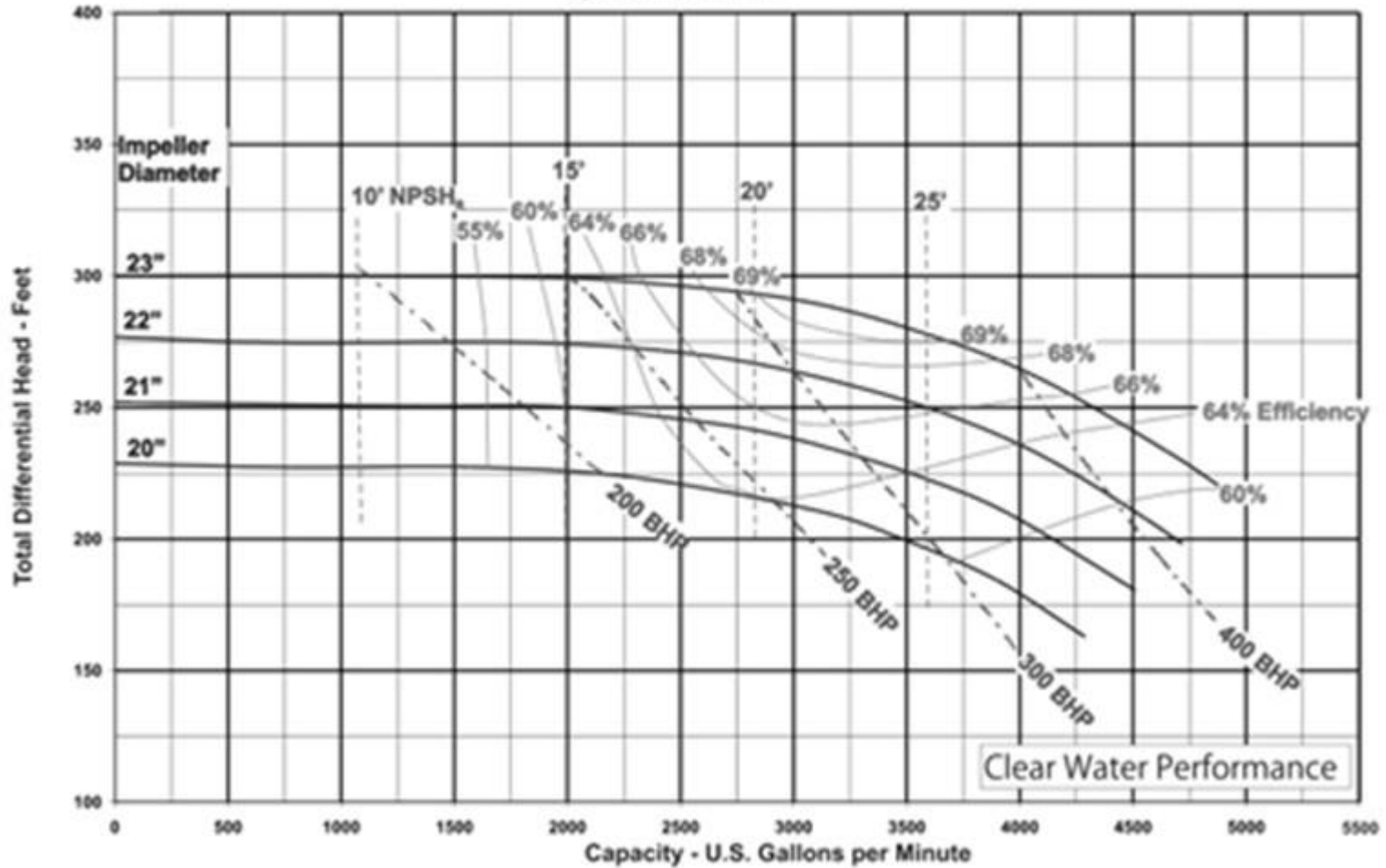

12X10-23

PRNM 12x10-23

Speed: 1400 RPM

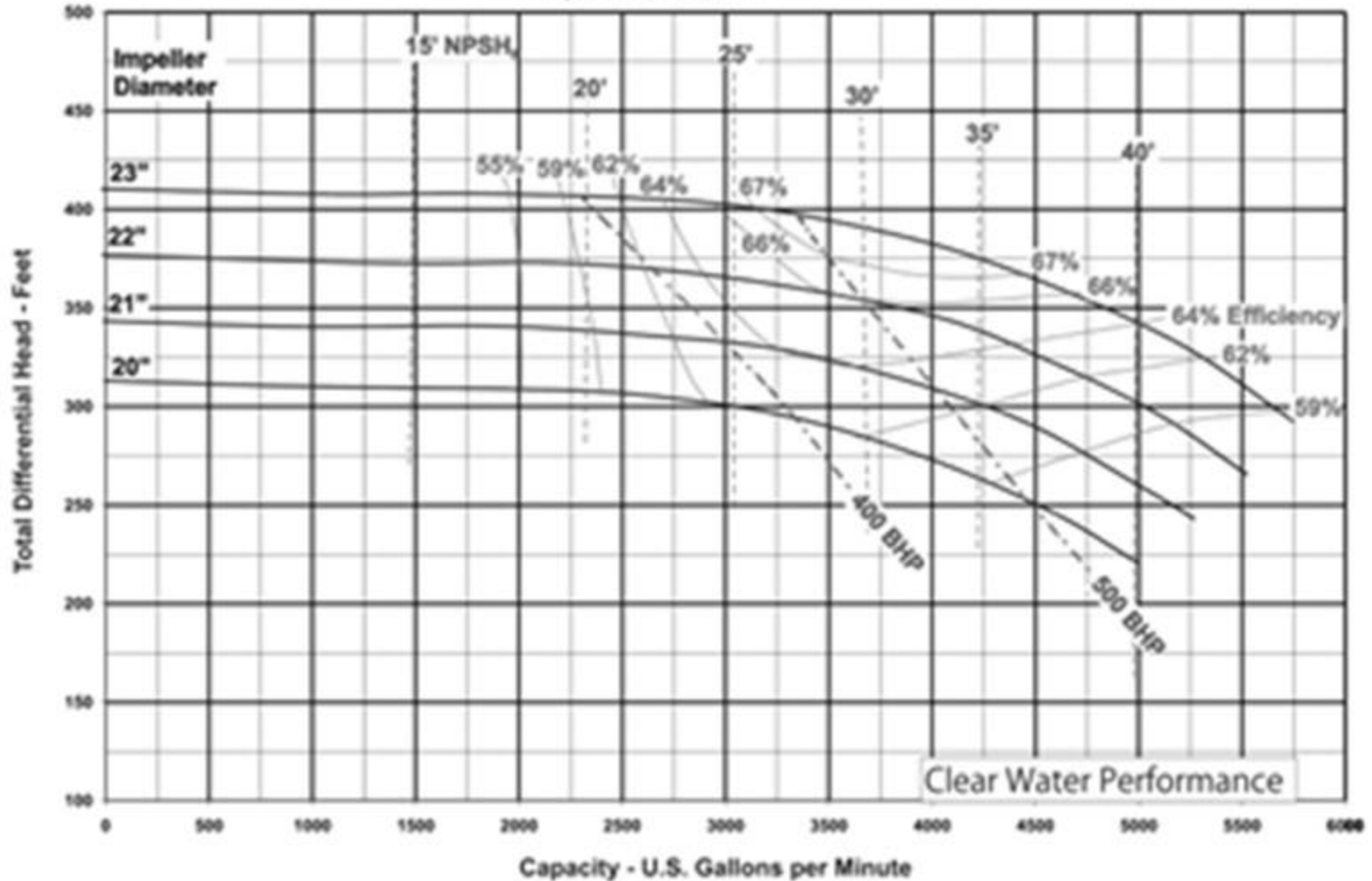

ISO5199 PIH Chemical Pumps

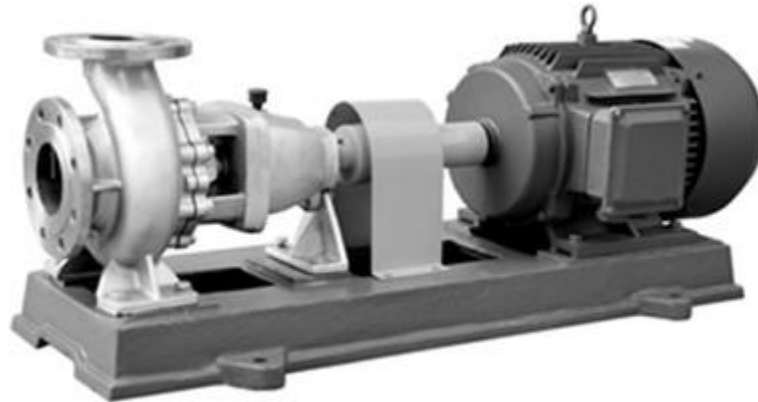

ISO5199 Standard PIH Series single stage horizontal end suction, top discharge overhung process pumps.

Capacities: 6.3m³/h~1200m³/h

Heads: 5m~125m

Pressures to 1.6 Mpa

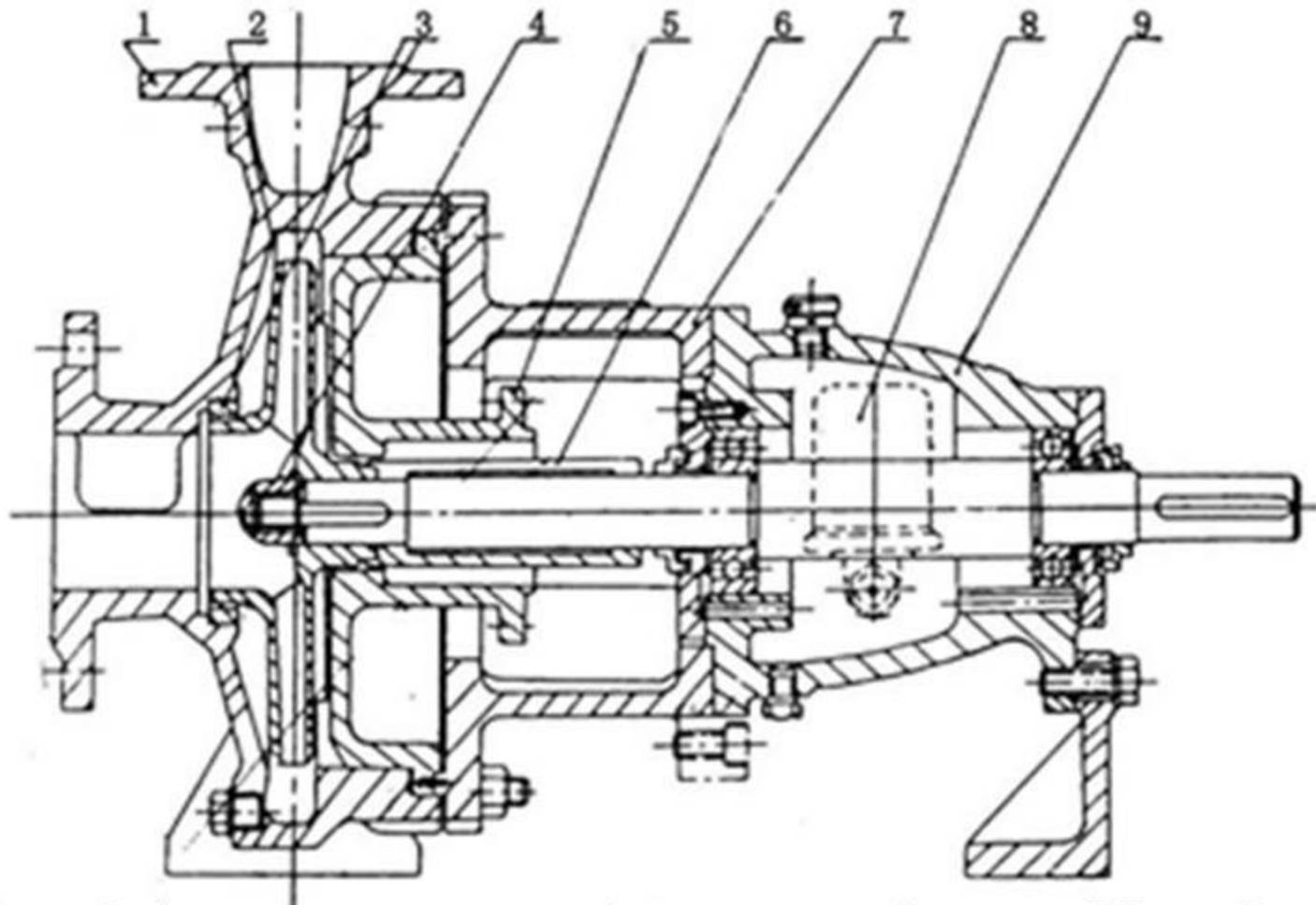

1.Pump Casing 2.Impeller 3.Seal-ring 4.Impeller Nut 5.Pump Cover
6.Seal Part 7.Mid.Bracekt 8.Shaft 9.Hanging stand

PIH series chemical centrifugal pump spectrum

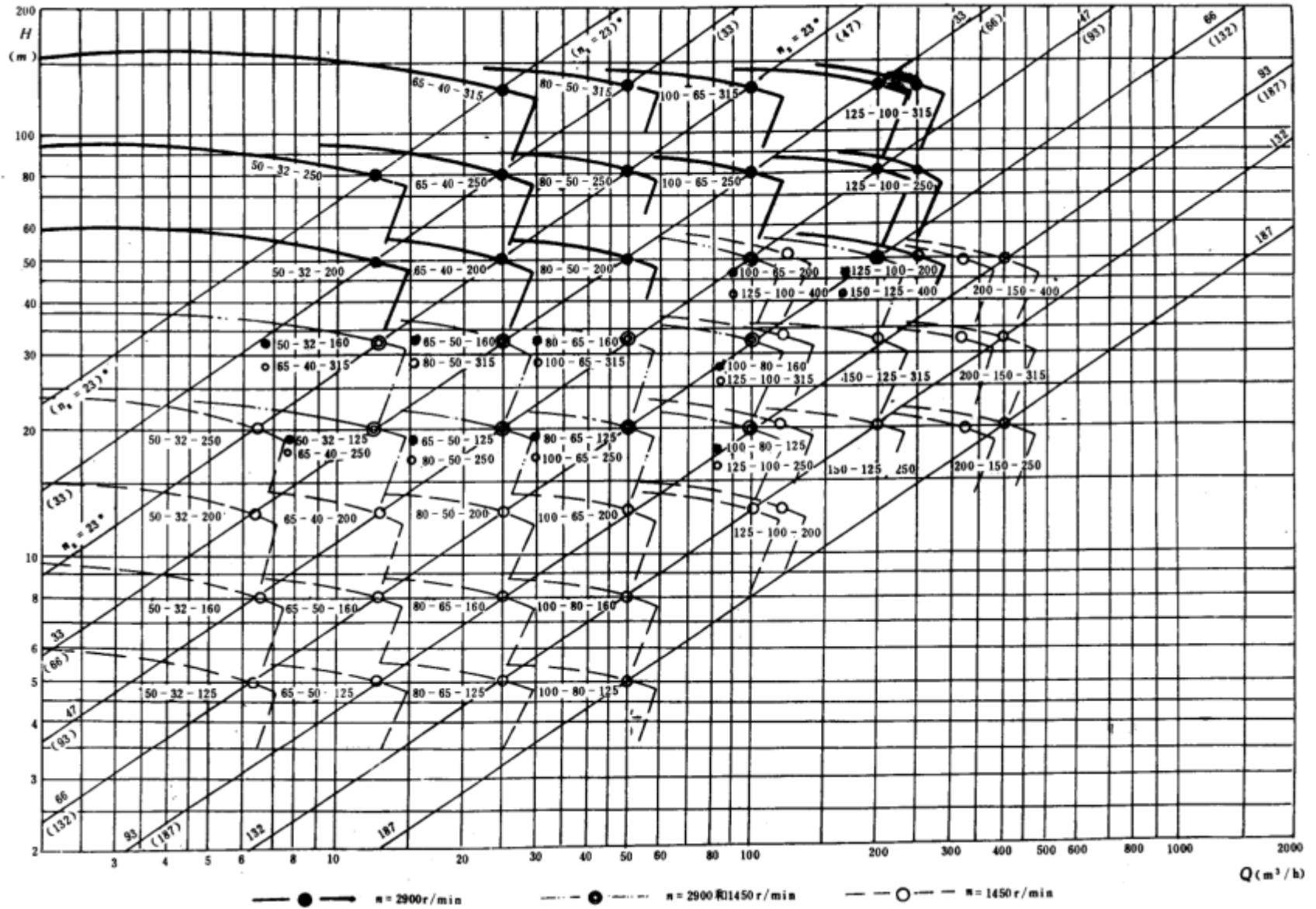

ANSI B73.1 Chemical Process Pumps

Chemical Flow Transfer

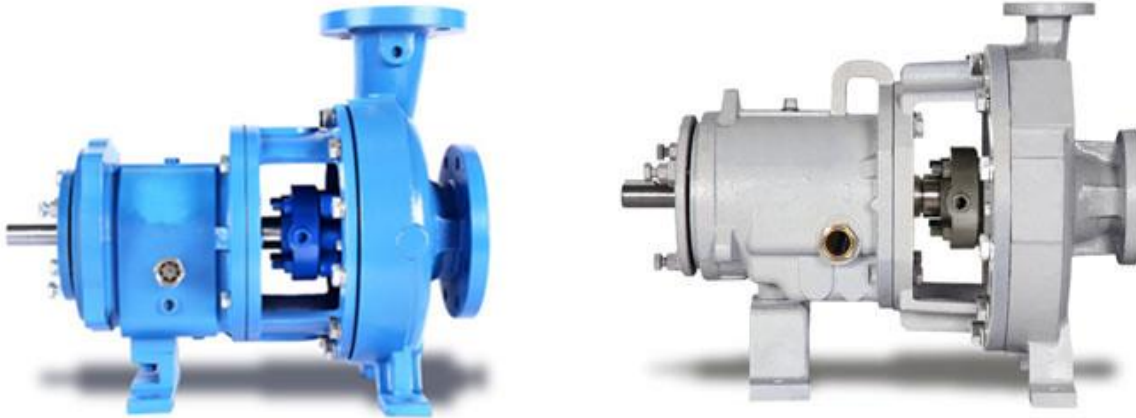

Precision Pumps manufactures ANSI B73.1 Standard Chemical Process Pumps as well as Aftermarket Parts.

G 3196 Series / ANSI Pumps



Since it's first introduced in 1961, it immediately became the standard in the industry. Wildly used in chemical, petrochemical, pulp & paper, primary metals, food & beverage and general industries. The wet end parts are available in all standard stainless steels: CF8M, CD4MCu, CN7M plus higher alloys form HC up to titanium.

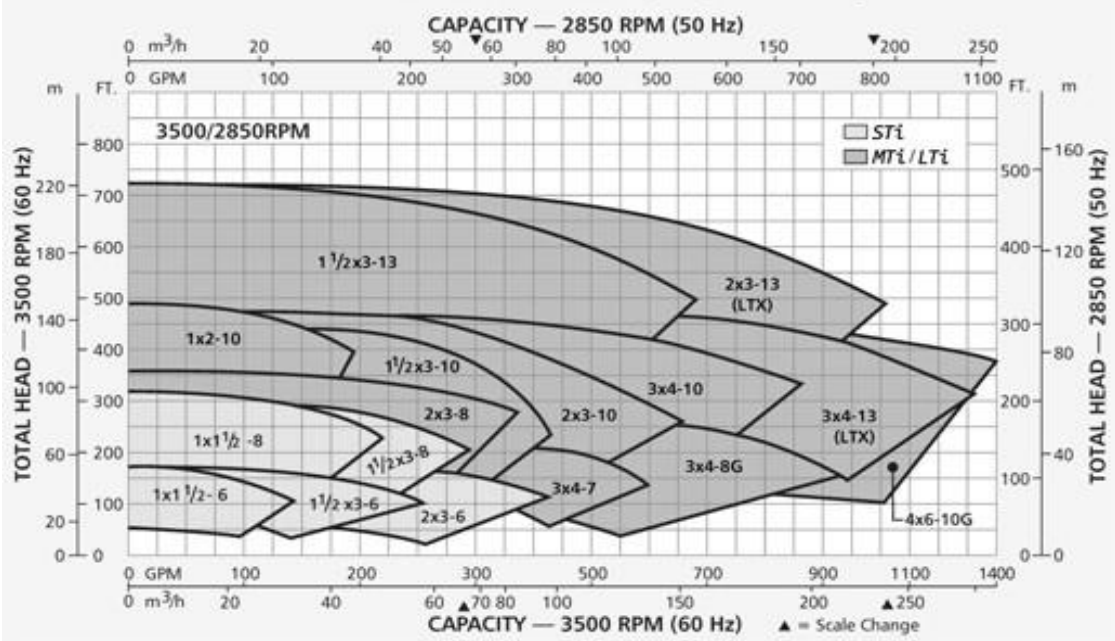
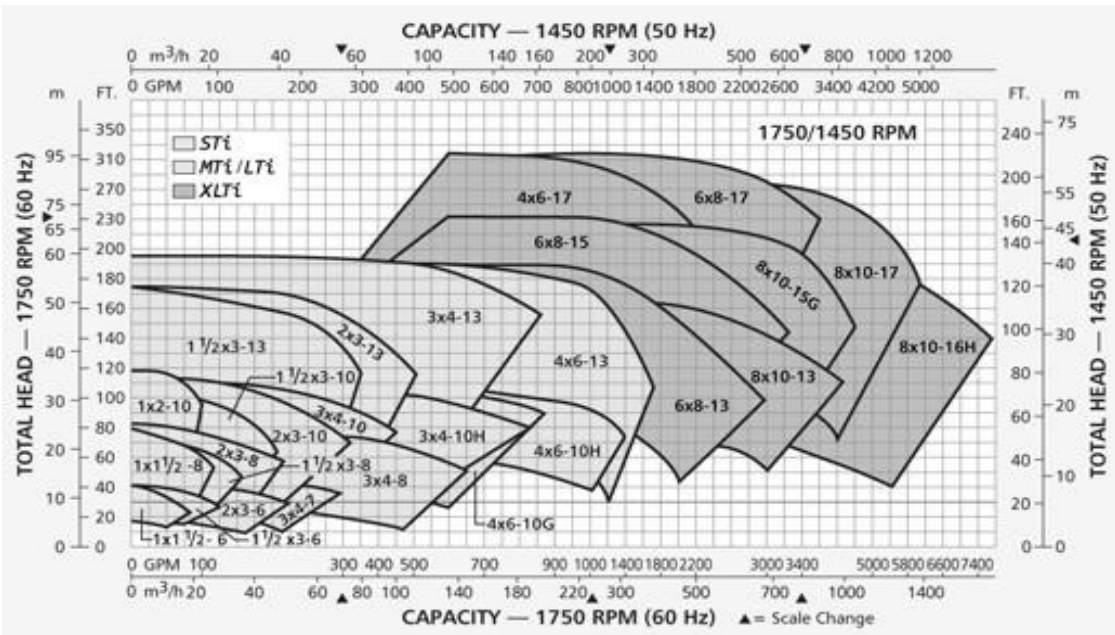

Capacities to 7000 GPM (1590 m³ /h)
 Heads to 730 feet (223 m)
 Temperatures to 700° F (371° C)
 Pressures to 375 PSIG (26 bar)

Application:

- Chemical Processing**
- General Industries**
- Mining**
- Water Resources**
- Power Generation**
- Primary Metals**
- Pulp and Paper**
- Oil and Gas**

D Mark III Series / ANSI Pumps

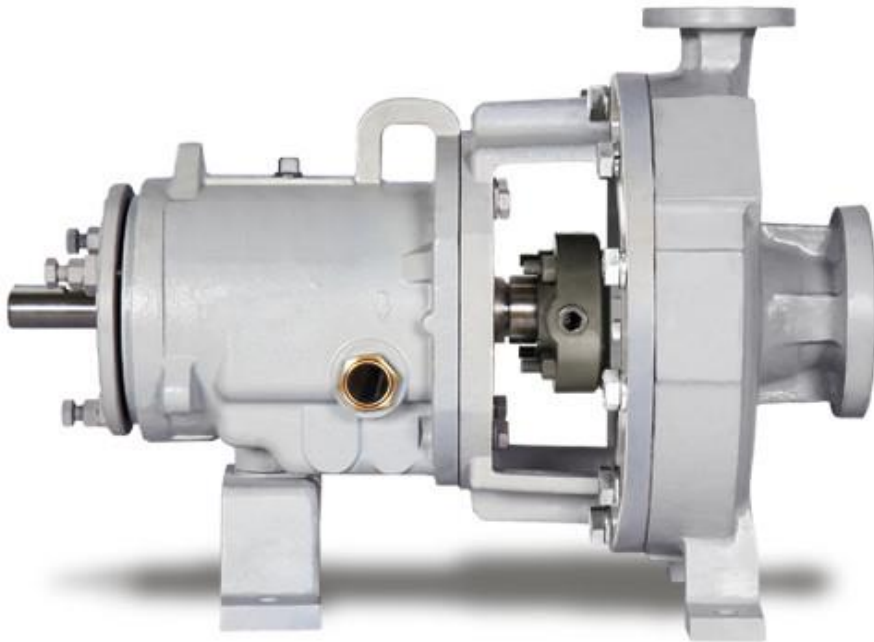

Reverse Vane Impeller is the only impeller design that offers repeatable pump performance throughout the life of the pump.

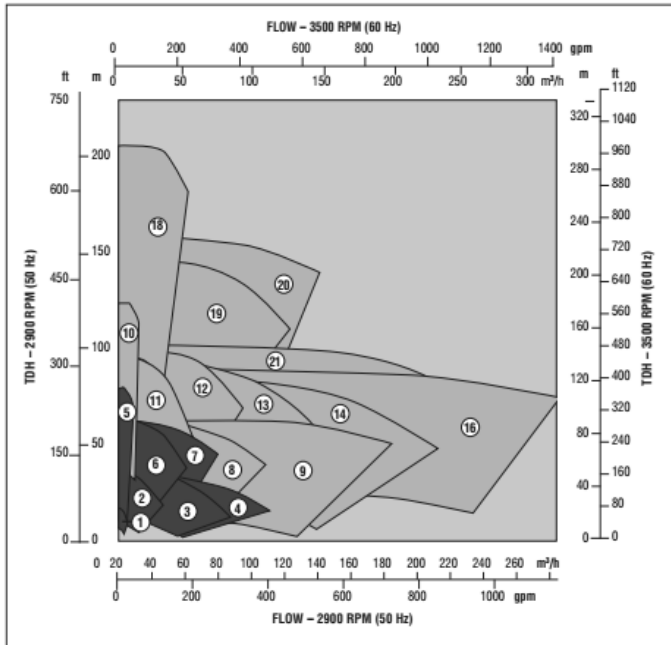

Mark 3 Standard Group 1

- ① 1½x1LF-4
- ② 1½x1-6
- ③ 3x1½-6
- ④ 3x2-6
- ⑤ 1½x1LF-8
- ⑥ 1½x1-8
- ⑦ 3x1½-8

Mark 3 Standard Group 2

- ⑧ 3x2-8
- ⑨ 4x3-8
- ⑩ 2x1LF-10
- ⑪ 2x1-10A
- ⑫ 3x1½-10A
- ⑬ 3x2-10A
- ⑭ 4x3-10
- ⑮ 4x3-10H
- ⑯ 6x4-10
- ⑰ 6x4-10H
- ⑱ 3x1½LF-13
- ⑲ 3x1½-13
- ⑳ 3x2-13
- ㉑ 4x3-13
- ㉒ 4x3-13HH
- ㉓ 6x4-13A

Mark 3 Standard Group 3

- ⑳ 8x6-14A
- ㉑ 10x8-14
- ㉒ 6x4-16
- ㉓ 8x6-16A
- ㉔ 10x8-16
- ㉕ 10x8-16H
- ㉖ 10x8-17

Flows to 1400 m³/h (6160 gpm)
 Heads to 220 m (720 ft)
 Pressures to 25 bar (365 psi)
 Temperatures from -80° C
 (-110° F) to 400° C (752° F)

Application:

- Chemical Processing**
- General Industries**
- Mining**
- Water Resources**
- Power Generation**
- Primary Metals**
- Pulp and Paper**
- Oil and Gas**

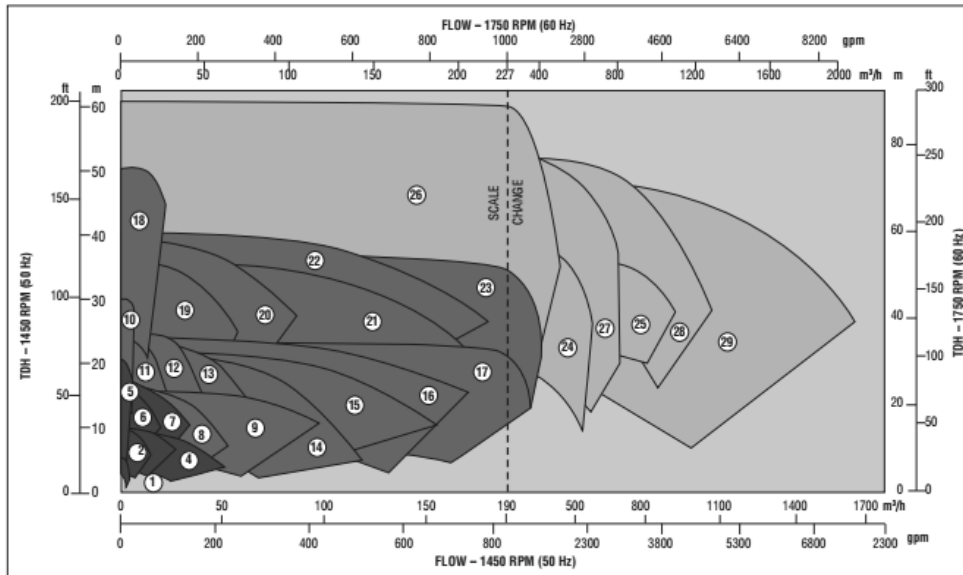

Aftermarket/Replacement Parts



G 3196 Spare Parts



D Mark III Spare Parts

G 3196 Spare Parts



G 3196 SERIES CASINGS

CASING			
Part #	Size	Model	OEM Part #
G1A01	1x1.5-6	3196 STX	104554
G1B01	1.5x3-6	3196 STX	104555
G1C01	2x3-6	3196 STX	105204
G1D01	1x1.5-8	3196 STX	104556
G1E01	1.5x3-8	3196 STX	104557
G2F01	2x3-8	3196 MTX	24741
G2G01	3x4-8	3196 MTX	24743
G2GG01	3x4-8G	3196 MTX	24745
G2H01	1x2-10	3196 MTX	104878
G2J01	1.5x3-10	3196 MTX	24960
G2L01	2x3-10	3196 MTX	24961
G2N01	3x4-10	3196 MTX	24962
G2P01	3x4-10H	3196 MTX	D00452A02
G2Q01	4x6-10	3196 MTX	25189
G2R01	4x6-10H	3196 MTX	D03123A
G2S01	1.5x3-13	3196 MTX	24963
G2T01	2x3-13	3196 MTX	D02450A
G2U01	3x4-13	3196 MTX	24965
G2W01	4x6-13	3196 MTX	D04930A
G3A01	6x8-13	3196 XLTX	25450
G3B01	8x10-13	3196 XLTX	D02488A02
G3C01	6x8-15	3196 XLTX	25494
G3D01	8x10-15	3196 XLTX	2555
G3E01	8x10-15G	3196 XLTX	25665

G 3196 SERIES IMPELLERS

IMPELLER			
Part #	Size	Model	OEM Part #
G1A03	1x1.5-6	3196 STX	76781
G1B03	1.5x3-6	3196 STX	76792
G1C03	2x3-6	3196 STX	0B10176
G1D03	1x1.5-8	3196 STX	76793
G1E03	1.5x3-8	3196 STX	76794
G2F03	2x3-8	3196 MTX	100161
G2G03	3x4-8	3196 MTX	100163
G2GG03	3x4-8G	3196 MTX	100165
G2H03	1x2-10	3196 MTX	0B10009
G2J03	1.5x3-10	3196 MTX	100593
G2L03	2x3-10	3196 MTX	100595
G2N03	3x4-10	3196 MTX	100597
G2P03	3x4-10H	3196 MTX	0C00262A02
G2Q03	4x6-10	3196 MTX	101528
G2R03	4x6-10H	3196 MTX	0C02521A
G2S03	1.5x3-13	3196 MTX	100537
G2T03	2x3-13	3196 MTX	100539
G2U03	3x4-13	3196 MTX	0B10542
G2W03	4x6-13	3196 MTX	101500
G2LH03	1x2-10	3196 LTX	10414620
G2LJ03	1.5X3-10	3196 LTX	10414622
G2LL03	2X3-10	3196 LTX	10414616
G2LS03	1.5X3-13	3196 LTX	0104146A2
G2LT03	2x3-13	3196 LTX	0B10588
G2LU03	3x4-13	3196 LTX	0B10591
G2LW03	4x6-13	3196 LTX	10414611
G3A03	6x8-13	3196 XLTX	103609
G3B03	8x10-13	3196 XLTX	0D02490A02
G3C03	6x8-15	3196 XLTX	256116
G3D03	8x10-15	3196 XLTX	256119
G3E03	8x10-15G	3197 XLTX	256122

G 3196 SERIES COVERS

COVER			
Part #	Size	Model	OEM Part #
G1A06	6"	3196 STX	R104562
G1A06B	6"	3196 STX	RC04056A01
G1B06	8"	3196 STX	R104564
G1B06B	8"	3196 STX	RC04057A01
G2F06	8"	3196 MTX	R100788
G2F06B	8"	3196 MTX	RC04058A01
G2H06	10"	3196 MTX	R100585
G2H06B	10"	3196 MTX	RC04059A01
G2S06	13"	3196 MTX	R100529
G2S06B	13"	3196 MTX	RC04060A01
G3A06	13"	3196 XLTX	R104707
G3A06B	13"	3196 XLTX	RC04063A01
G3E06	15"	3196 XLTX	R104710
G3E06B	15"	3196 XLTX	RC04064A01

G 3196 SERIES ADAPTOR

ADAPTOR			
Part #	Size	Model	OEM Part #
G1C08	STX 8"	3196 STX	76782
G2F08	MTX 8"	3196 MTX/LTX	R26292
G2H08	MTX 10"	3196 MTX/LTX	R26293
G2S08	MTX 13"	3196 MTX/LTX	R26294
G3A08	XLTX 13"	3196 XLTX	R102812
G3F08	XLTX 15"	3196 XLTX	R102814

G 3196 SERIES FRAME

FRAME			
Part #	Size	Model	OEM Part #
G119	STX	3196 STX	RD04539AA
G219	MTX	3196 MTX	RD04540AA
G2L19	LTX	3196 LTX	RD04548AA
G319	XLTX	3196 XLTX	RE00666AA

G 3196 SERIES BEARING HOUSING

BEARING HOUSING			
Part #	Size	Model	OEM Part #
G112	STX	3196 STX	C03340A
G212	MTX	3196 MTX	D04872A
G2L12	LTX	3196 LTX	D04628A
G312	XLTX	3196 XLTX	D04871A

G 3196 SERIES FEET

FEET			
Part #	Size	Model	OEM Part #
G2H09	MTX 8 & 10"	3196 MTX	B02092A
G2S09	MTX 10H & 13"	3196 MTX	B02091A
G3E09	XLTX 15"	3196 XLTX	C04366A

G 3196 SERIES SHAFTS

SHAFT			
Part #	Model	Material	OEM Part #
G115	STX	316ss	R104434
G115S	3196 STX	4140 / 316ss	R104435
G215	MTX	316ss	R104731
G215S	3196 MTX	4140 / 316ss	R104733
G2L15	LTX	316ss	R11062
G2L15S	3196 LTX	4140 / 316ss	RC03044A
G315	XLTX	316ss	R103615
G315S	3196 XLTX	4140 / 316ss	R103614

G 3196 SERIES SLEEVES

SLEEVE			
Part #	Model	Material	OEM Part #
G117	3196 STX	316ss	76772X
G217	3196 MTX	316ss	73705X
G2L17	3196 LTX	316ss	91967X
G317	3196 XLTX	316ss	76230

D Mark III Spare Parts

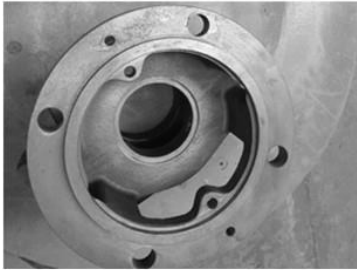
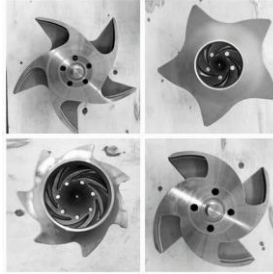

D Mark III SERIES CASINGS

CASING			
Part #	Size	Model	OEM Part #
D1A01	1.5x1-62	Mark III Group 1	DY50772
D1B01	3x1.5-62	Mark III Group 1	DY50794A
D1C01	3x2-62	Mark III Group 1	DY50733A
D1D01	1.5x1-82	Mark III Group 1	DY52981A
D1E01	3x1.5-82	Mark III Group 1	DY50659A
D2F01	3x2-82	Mark III Group 2	DY46070A
D2G01	4x3-82	Mark III Group 2	DY46161A
D2H01	2x1-10A	Mark III Group 2	DY46950A
D2K01	3x1.5-10A	Mark III Group 2	DY50995A
D2L01	3x2-10	Mark III Group 2	CY21802A
D2M01	3x2-10A	Mark III Group 2	DY51040A
D2N01	4x3-10	Mark III Group 2	CY22235A
D2P01	4x3-10H	Mark III Group 2	CY22385A
D2Q01	6x4-10	Mark III Group 2	DY47208A
D2R01	6x4-10H	Mark III Group 2	DY51022A
D2S01	3x1.5-13	Mark III Group 2	CY21853A
D2T01	3x2-13	Mark III Group 2	CY22312A
D2U01	4x3-13	Mark III Group 2	CY22344A
D2W01	6x4-13A	Mark III Group 2	DY33074A
D3A01	8x6-14A	Mark III Group 3	DY32218AA
D3B01	10x8-14	Mark III Group 3	DY48876AA
D3C01	6x4-16	Mark III Group 3	DY51013A
D3D01	8x6-16	Mark III Group 3	DY30546A
D3E01	8x6-16A	Mark III Group 3	DY48891AA
D3F01	10x8-16	Mark III Group 3	DY48899AA
D3G01	10x8-16H	Mark III Group 3	DY48925AA

D Mark III SERIES IMPELLERS

IMPELLER			
Part #	Size	Model	OEM Part #
D1A03	1.5x1-62	Mark III Group 1	MY50798A62
D1B03	3x1.5-62	Mark III Group 1	MY50746A62
D1C03	3x2-62	Mark III Group 1	MY50723A62
D1D03	1.5x1-82	Mark III Group 1	MY50754A82
D1E03	3x1.5-82	Mark III Group 1	MY50656A82
D2F03	3x2-82	Mark III Group 2	MY46066A82
D2G03	4x3-82	Mark III Group 2	MY46157A82
D2H03	2x1-10A	Mark III Group 2	MY46952AA100
D2K03	3x1.5-10A	Mark III Group 2	MY51157A100
D2L03	3x2-10	Mark III Group 2	MY36862A100
D2M03	3x2-10A	Mark III Group 2	MY51049A100
D2N03	4x3-10	Mark III Group 2	MY35641AA100
D2P03	4x3-10H	Mark III Group 2	MY36877A100
D2Q03	6x4-10	Mark III Group 2	MY47210AA100
D2S03	3x1.5-13	Mark III Group 2	MY36649AA130
D2T03	3x2-13	Mark III Group 2	MY49112A130
D2U03	4x3-13	Mark III Group 2	MY36847AA130
D2V03	4x3-13HH	Mark III Group 2	MY50171AA130
D2W03	6x4-13A	Mark III Group 2	MY36846AA130
D3A03	8x6-14A	Mark III Group 3	MY40103AA140
D3B03	10x8-14	Mark III Group 3	MY48879A140
D3C03	6x4-16	Mark III Group 3	MY51017A160
D3D03	8x6-16	Mark II Group 3	MY39056AA160
D3E03	8x6-16A	Mark III Group 3	MY48888A160
D3F03	10x8-16	Mark II Group 3	MY48902A160
D3G03	10x8-16H	Mark III Group 3	MY48928A160

D Mark III SERIES COVERS

COVER			
Part #	Size	Model	OEM Part #
D1A06	6 & 8"	Mark 3 Group 1	CY50617A
D1A06B	6 & 8"	Mark 3 Group 1	CY52022A
D1A06D	6 & 8"	Mark 3 Group 1	CY53428A
D1A06E	6 & 8"	Mark 3 Group 1	CY53429A
D2F06	8"	Mark 3 Group 2	CY46072A
D2F06B	8"	Mark 3 Group 2	CY52024A
D2F06D	8"	Mark 3 Group 2	CY53432A
D2F06E	8"	Mark 3 Group 2	CY53433A
D2H06	10"	Mark 3 Group 2	CY21805A
D2H06B	10"	Mark 3 Group 2	DY52026A
D2H06D	10"	Mark 3 Group 2	DY53439A
D2H06E	10"	Mark 3 Group 2	DY53440A
D2S06	13"	Mark 3 Group 2	DY21855A
D2S06B	13"	Mark 3 Group 2	DY52028A
D2S06D	13"	Mark 3 Group 2	DY53442A
D2S06E	13"	Mark 3 Group 2	DY53443A
D3A06	14"	Mark 3 Group 3	DY28284AA
D3A06B	14"	Mark 3 Group 3	DY52030A
D3A06D	14"	Mark 3 Group 3	DY53499A
D3A06E	14"	Mark 3 Group 3	DY53501A
D3E06	16"	Mark 3 Group3	DY27457AA
D3E06B	16"	Mark 3 Group 3	DY52032A
D3E06D	16"	Mark 3 Group 3	DY53502A
D3E06E	16"	Mark 3 Group 3	DY53504A

D1A06=Cylindrical Bore Small(CBS)

D1A06B=Cylindrical Bore Large(CBL)

D1A06D=Flow Modifier Small(FMS)

D1A06E=Flow Modifier Large(FML)

D Mark III SERIES ADAPTOR

Part #	Size	Model	OEM Part #
D2F08	8"	Mark 3 Group 2	DY46074AAP
D2H08	10"	Mark 3 Group 2	DY21806ACP
D2S08	13"	Mark 3 Group 2	DY21857ABP
D3A08	14"	Mark 3 Group 3	DY28285ACP
D3E08	16"	Mark 3 Group 3	DY27463ACP

D Mark III SERIES FRAME

FRAME			
Part #	Size	Model	OEM Part #
D119	Group 1	Mark III	DY55721B
D219	Group 2	Mark III	DY55718A
D319	Group 3	Mark III	DY55723A

D Mark III SERIES BEARING HOUSING

BEARING HOUSING			
Part #	Size	Model	OEM Part #
D112	Group 1	Mark III	CY55739AP
D212	Group 2	Mark III	CY55742AP
D312	Group 3	Mark III	DY55743AP

D Mark III SERIES BEARING FEET

FEET			
Part #	Size	Model	OEM Part #
D1A09	6" & 8"	Mark IIIA	CY55732AK
D1A09D	3x1.5-8	Mark IIIA	CY55733AK
D2F09	8" & 10" small	Mark IIIA	CY55736AK
D2S09	10" large & 13"	Mark IIIA	CY55737AK
D3A09	Group 3	Mark IIIA	CY55738AK

D Mark III SERIES SHAFTS

SHAFT			
Part #	Model	Material	OEM Part #
D115	Mark 3 Group 1	316ss	CY50683A
D115S	Mark 3 Group 1	4140	CY50686A
D215	Mark 3 Group 2	316ss	CY21361BA
D215S	Mark 3 Group 2	4140	CY32768B
D315	Mark 3 Group 3	316ss	CY50463A
D315S	Mark 3 Group 3	4140	CY50467A

D Mark III SERIES SLEEVES

SLEEVE			
Part #	Model	Material	OEM Part #
D117	Mark 3 Group 1	316ss	AY50691A
D217	Mark 3 Group 2	316ss	AY38913AA
D317	Mark 3 Group 3	316ss	BY39477A